

Cinema Mid-High Loudspeaker System

QSC

User Manual

MH-1060 10" (254 mm) mid, 2.4" (60 mm) compression driver

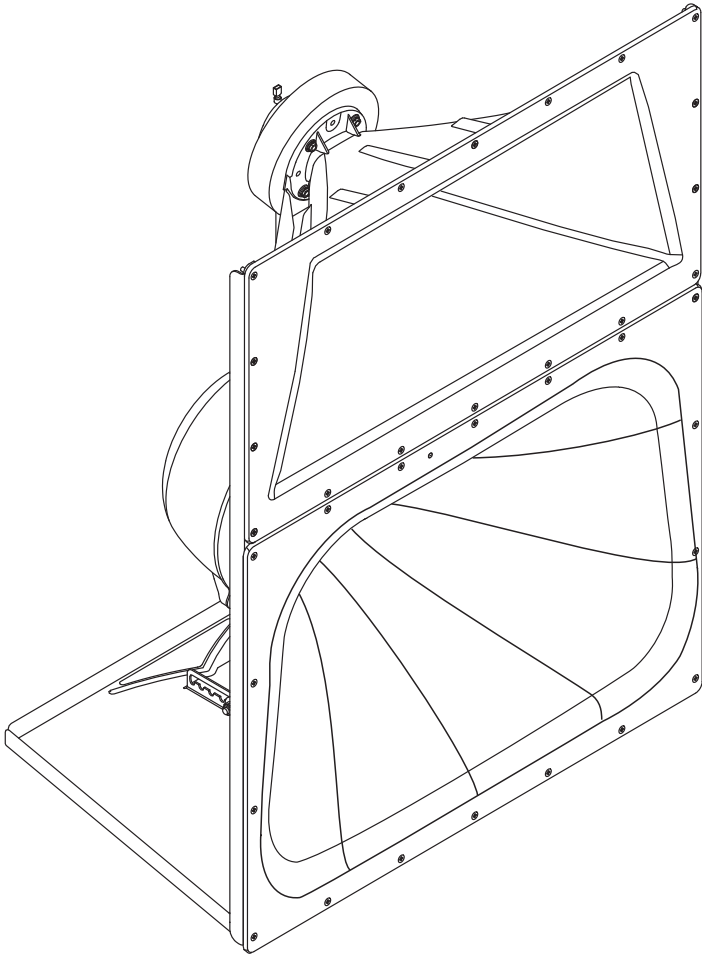

TD-001524-01-B



EXPLANATION OF SYMBOLS

The term “WARNING!” indicates instructions regarding personal safety. If the instructions are not followed the result may be bodily injury or death.

The term “CAUTION!” indicates instructions regarding possible damage to physical equipment. If these instructions are not followed, it may result in damage to the equipment that may not be covered under the warranty.

The term “IMPORTANT!” indicates instructions or information that are vital to the successful completion of the procedure.

The term “NOTE” is used to indicate additional useful information.



NOTE: The intent of the lightning flash with arrowhead symbol in a triangle is to alert the user to the presence of un-insulated “dangerous” voltage within the product’s enclosure that may be of sufficient magnitude to constitute a risk of electric shock to humans.



NOTE: The intent of the exclamation point within an equilateral triangle is to alert the user to the presence of important safety, and operating and maintenance instructions in this manual.



IMPORTANT SAFETY INSTRUCTIONS



1. Read these instructions.
2. Keep these instructions.
3. Heed all warnings.
4. Follow all instructions.
5. Do not use this apparatus near water.
6. Clean only with a dry cloth.
7. Do not block any ventilation opening. Install in accordance with the manufacturer’s instructions.
8. Do not install near any heat sources such as radiators, heat registers, stoves, or other apparatus (including amplifiers) that produce heat.
9. Only use attachments/accessories specified by the manufacturer.
10. Refer all servicing to qualified service personnel. Servicing is required when the apparatus has been damaged in any way, such as power-supply cord or plug is damaged, liquid has been spilled or objects have fallen into the apparatus, the apparatus has been exposed to rain or moisture, does not operate normally, or has been dropped.
11. Adhere to all applicable, local codes.
12. Consult a licensed, professional engineer when any doubt or questions arise regarding a physical equipment installation.
13. Do not use any aerosol spray, cleaner, disinfectant or fumigant on, near or into the apparatus. Clean only with a dry cloth.
14. Do not submerge the apparatus in water or liquids.
15. Keep ventilation opening free of dust or other matter.

Maintenance and Repair



WARNING!: Advanced technology, e.g., the use of modern materials and powerful electronics, requires specially adapted maintenance and repair methods. To avoid a danger of subsequent damage to the apparatus, injuries to persons and/or the creation of additional safety hazards, all maintenance or repair work on the apparatus should be performed only by a QSC authorized service station or an authorized QSC International Distributor. QSC is not responsible for any injury, harm or related damages arising from any failure of the customer, owner or user of the apparatus to facilitate those repairs.

Introduction

The MH-1060 “mid-high pack” provides the mid and high frequency components of three-way screen channel loudspeaker systems for high performance cinema applications. They were designed to operate with and be directly mounted on QSC’s cinema low-frequency enclosures.

Mid frequencies are reproduced with a 10” (254 mm) high-efficiency, phase-ring loaded driver mounted on a custom designed cinema horn. The high-frequency driver is a large format, 2.4” (60 mm) titanium diaphragm compression driver mounted on a custom high-frequency cinema horn. The high frequency horn is a low-distortion waveguide providing highly articulate dialogue without coloration associated with conventional horn loudspeakers. Both horns feature broad horizontal and vertical coverage angles to ensure coverage of every seat in the auditorium. The driver assemblies are mounted on an adjustable pan and tilt bracket that has an integral aiming sight, simplifying installation.

The MH-1060 loudspeaker includes a crossover network with an 18 dB/octave electrical slope for the high-pass and a 12 dB/octave electrical slope for the low-pass. This seamlessly blends the high and mid frequency elements. Outboard processing is required to form the crossover between the LF and MH loudspeakers.

The MH-1060 components come pre-assembled to reduce field assembly time. Three bolts are all that are required to secure the mid-high assembly to the top of a QSC low-frequency enclosure.

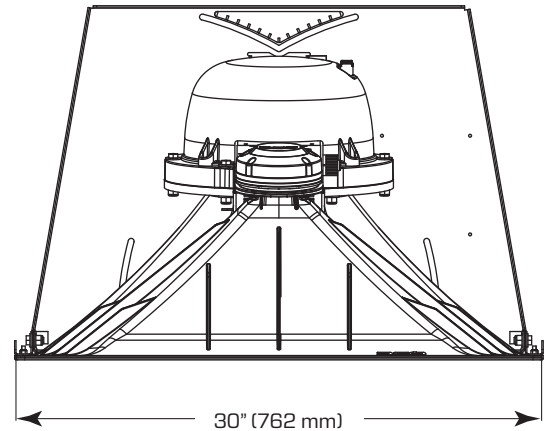

NOTE: Install in accordance with QSC’s instructions and a licensed, professional engineer. Only use attachments, mounts, accessories, or brackets specified by QSC, LLC Refer all servicing to qualified personnel. Servicing is required when the apparatus has been damaged in any way.



WARNING!: Before placing, installing, rigging, or suspending any speaker product, inspect all hardware, suspension, cabinets, transducers, brackets and associated equipment for damage. Any missing, corroded, deformed or non-load rated component could significantly reduce the strength of the installation, placement, or array. Any such condition severely reduces the safety of the installation and should be immediately corrected. Use only hardware which is rated for the loading conditions of the installation and any possible short-term unexpected overloading. Never exceed the rating of the hardware or equipment. Consult a licensed, professional engineer when any doubt or questions arise regarding a physical equipment installation.

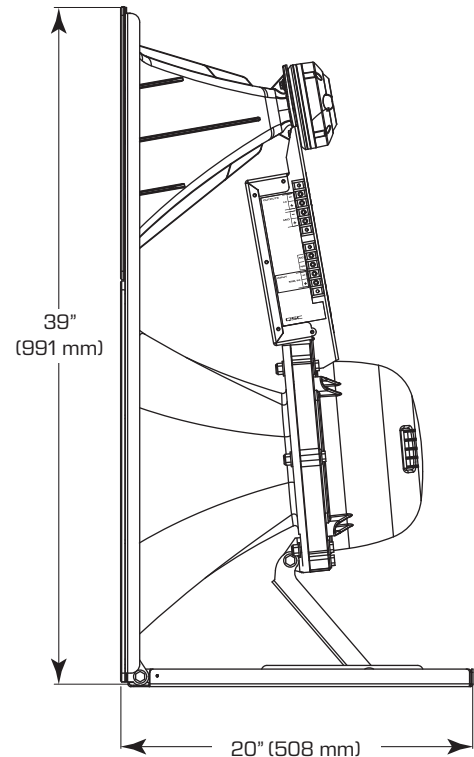

— Figure 1 —

Mounting

Attaching to Low Frequency Enclosure

The mid-high loudspeaker assembly attaches to the top of the QSC low frequency cabinet with three M8 bolts, 20 mm long, with lock washers. This hardware ships installed on the low frequency cabinet. We recommend the use of serviceable thread locking compound when installing the bolts to prevent loosening due to vibration. Do not fully tighten the mounting hardware before aiming (see below).

Aiming

Aim the horn in the horizontal plane (pan) before tightening the attachment hardware. Adjust the vertical tilt with the mid-high vertical adjustment bracket. The mid-high assembly is equipped with an aiming sight to assist in achieving desired coverage quickly and easily. For typical applications, the aim point should be the center seat in the back row of the auditorium. If the cinema screen has already been installed, a flashlight placed at the desired aiming point can be seen through the screen perforations in a darkened auditorium.

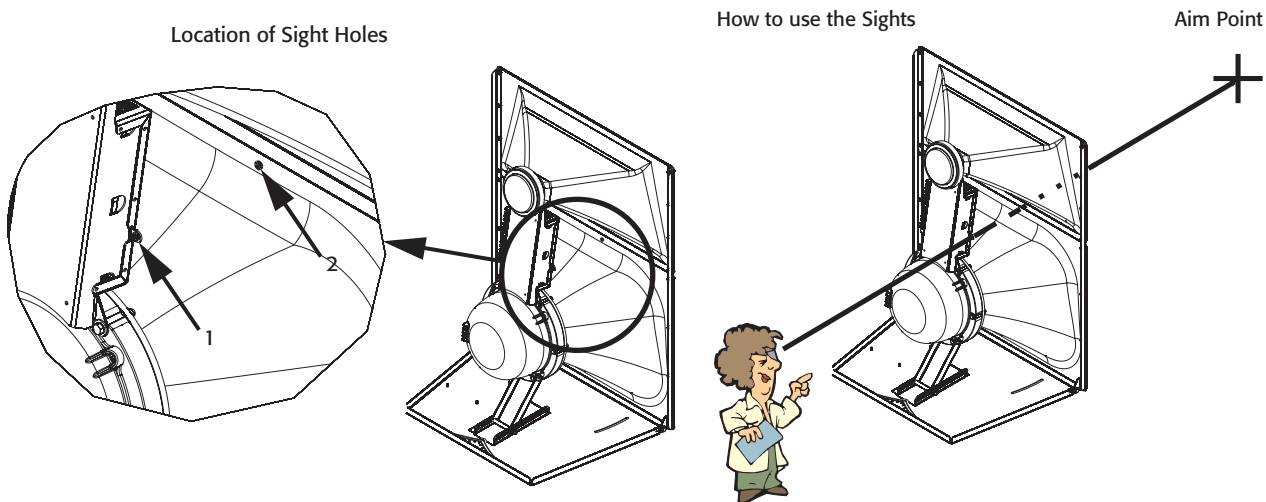

— Figure 2 —

— Figure 3 —

Connections



CAUTION! Do not connect amplifiers directly to the driver inputs! Always use the input terminal strip.

INPUT Terminals

The MH-1060 has barrier strip screw terminals that accept up to #10 AWG (6 mm²) stranded loudspeaker wire. Observe proper polarity. Use the largest wire size and shortest wire length for the application. *The signal applied to the mid high loudspeaker assembly must not contain low frequency content (below 200 Hz).*

OUTPUT Terminals

The OUTPUT terminals are factory-connected to the drivers. These terminals should ONLY be connected to their respective driver. Do not connect signals to these terminals as all crossover and equalization circuitry will be bypassed.



NOTE: Maintain proper loudspeaker connection polarity throughout the entire system for maximum performance. Do not apply full range signal (with <200 Hz content) to the MH-1060! Do not connect any signal to the upper sets of OUTPUT terminals.

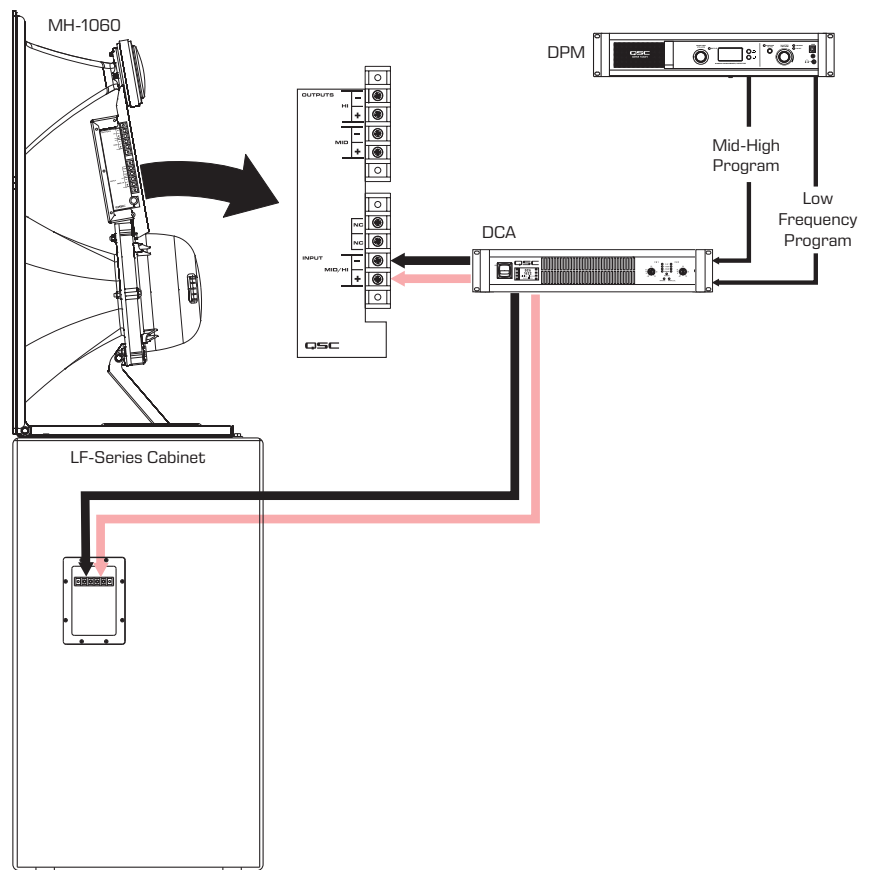

— Figure 4 —

Specifications

Subject to change without notice

Frequency Range	20 Hz – 20 kHz (Full Space, with QSC processing, 1/3 octave smoothing)
Nominal Coverage	90° horizontal X +20 to -30° vertical (50° total, adjustable mount provides for vertical plane adjustments. The horizontal plane can be adjusted by altering mounting position on the low frequency enclosure before tightening bolts.
DI:	9 dB (400 to 16 kHz average)
Q:	8 (400 to 16 kHz average)
Maximum Output:	126 dB calculated continuous and 132 dB calculated peak (based on nominal impedance)
Impedance:	8 ohms nominal
Maximum Input Power	Continuous Power (W): 200 W (based on nominal impedance)
Sensitivity	103 dB SPL, 1 W, 1 m (Based on 2.83 V at 1 m)
Crossover Frequencies	250 Hz or higher, 24 dB/octave
Crossover Network	2.2 kHz, 18 dB/octave high-pass and 12 dB/octave low-pass electrical slopes.
Connectors	Barrier strip screw terminals accept up to #10 AWG (6 mm ²) stranded wire. Two input terminals.
Transducers	
Mid Frequency	10" high efficiency midrange, phase-ring loaded.
High Frequency	1.4" (36 mm) exit, 2.4" (60 mm) voice coil, titanium diaphragm compression driver.
Mounting Hardware:	Attaches to top of the low frequency cabinet using three M8, 20 mm long bolts.
Size (HWD)	39 x 30 x 20 inches (991 x 762 x 508 mm)
Weight	82 lb. (37.2 kg) net



Mailing Address:

QSC, LLC
1675 MacArthur Boulevard
Costa Mesa, CA 92626-1468 U.S.

Telephone Numbers:

Main Number: +1.714.754.6175
Sales & Marketing: +1.714.957.7100 or toll free (U.S. only) 800.854.4079
Customer Service: +1.714.957.7150 or toll free (U.S. only) 800.772.2834

Facsimile Numbers:

Sales & Marketing FAX: +1.714.754.6174
Customer Service FAX: +1.714.754.6173

World Wide Web:

www.qsc.com/cinema/

E-mail:

info@qsc.com
cinematechsupport@qsc.com