

THIS DOCUMENT CONTAINS PROPRIETARY INFORMATION WHICH IS THE PROPERTY OF QSC AUDIO PRODUCTS. THAT MAY NOT BE DISCLOSED, REPRODUCED OR USED WITHOUT EXPRESS WRITTEN CONSENT FROM QSC AUDIO PRODUCTS.

REVISIONS			
REV	DESCRIPTION	BY	DATE
A	RELEASE FOR SALES AND MARKETING	SS	14-SEP-15

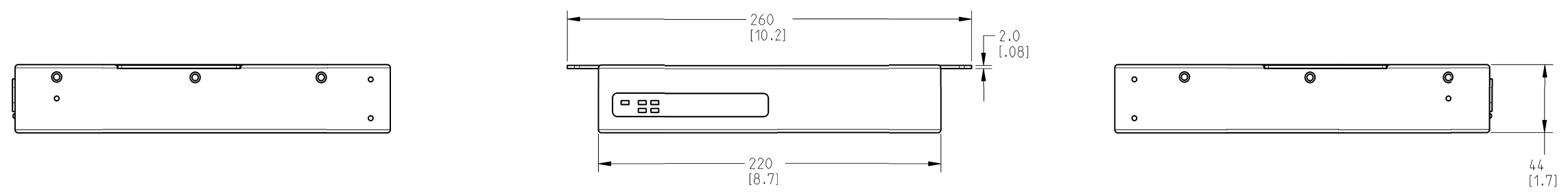

FRONT VIEW

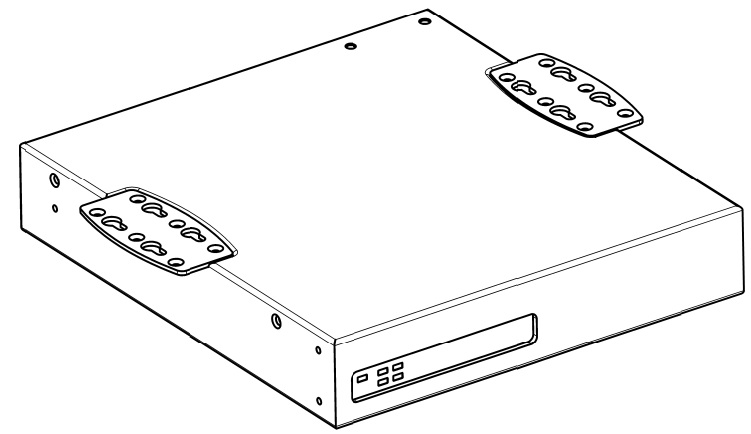
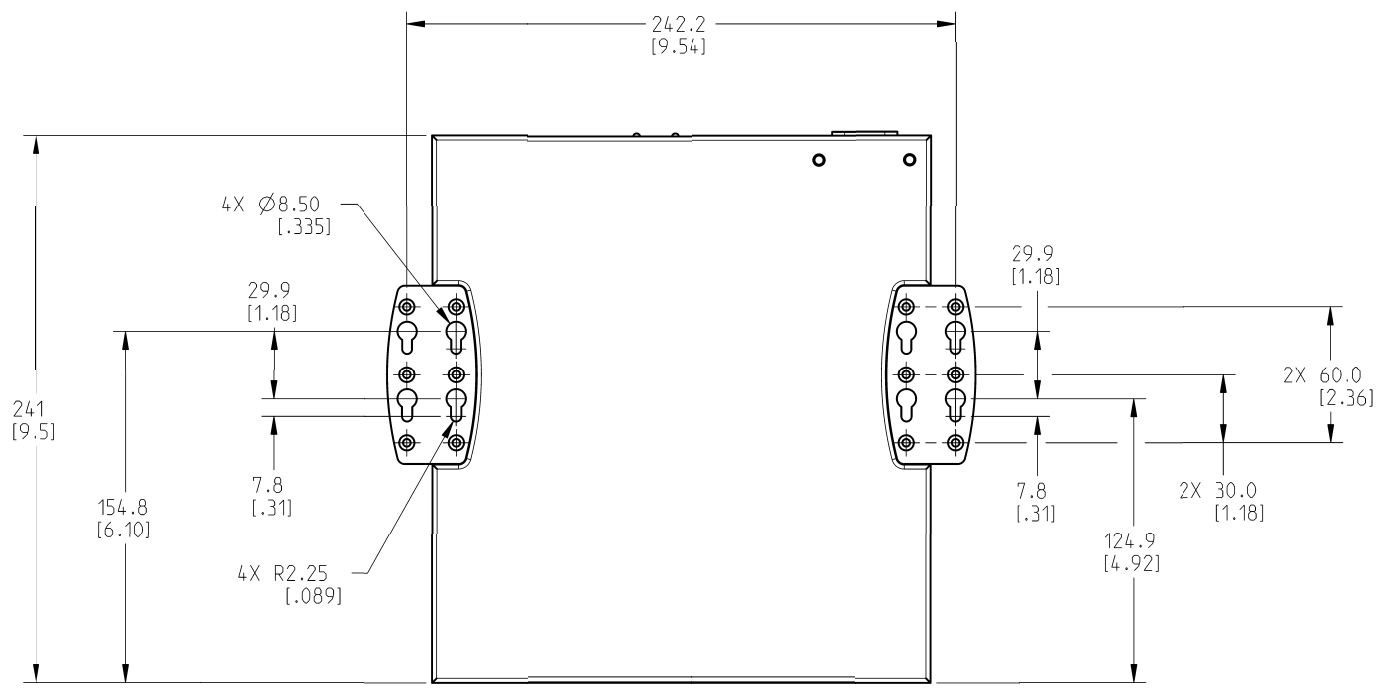
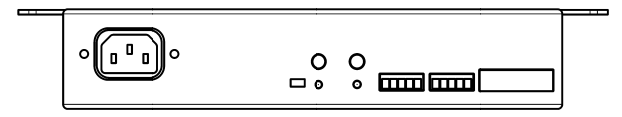

REAR VIEW

5. MEETS UL2043 WITH PLENUM KIT FG-000995-00.
4. MEETS ENERGYSTAR REQUIREMENTS.
3. CHASSIS DESIGNED TO MEET 1U RACK MOUNT SPECIFICATION IEC60297-3-100.
2. FEATURES SYMMETRICAL ABOUT CENTERLINE.
1. NET WEIGHT OF SPA2-60 APPROX. 1.1 KG (3.5 LBS). HARDWARE IS ADDITIONAL WEIGHT.

NOTES: UNLESS OTHERWISE SPECIFIED.

UNLESS OTHERWISE SPECIFIED DIMENSIONS IN MILLIMETERS (IN) TOLERANCES ARE: DECIMALS .XX±.021 ANGLES .XX±.25(1.0°) ± 1/2 DEBURR EDGES .25 (.010) R MAX	DESIGNER	ENGINEERING SERVICES	QSC AUDIO PRODUCTS, LLC 1675 MACARTHUR BOULEVARD COSTA MESA, CA 92626			
	ENGINEER	-				
	TECHNICAL DIRECTOR	-				
	MANUFACTURING ENGINEER	-				
MATERIAL	-		SIZE	CAGE CODE	DRAWING NO.	REV
FINISH	-		D	00PW4	FG-002202-2D-D	A
DRAWING INFO: FG-002202-2D-D.A.1		SCALE: 0.600	DO NOT SCALE DRAWING		SHEET 1 OF 1	
MODEL INFO: FG-002202-3D-D.A.1						