

THIS DOCUMENT CONTAINS PROPRIETARY INFORMATION WHICH IS THE PROPERTY OF QSC AUDIO PRODUCTS. THAT MAY NOT BE DISCLOSED, REPRODUCED OR USED WITHOUT EXPRESS WRITTEN CONSENT FROM QSC AUDIO PRODUCTS.

REV	DESCRIPTION	EFF. DATE	CHK	APPROVED DATE
A	PROD RELEASE PER ECO 3743 AA	7-3-98		TS
B	REVISED PER ECO 3810 AA	11-13-98		TS11-12-9
C	REVISED PER ECO 4297 AA	5-15-00		

RAVE/RAPID RAVE DIGITAL

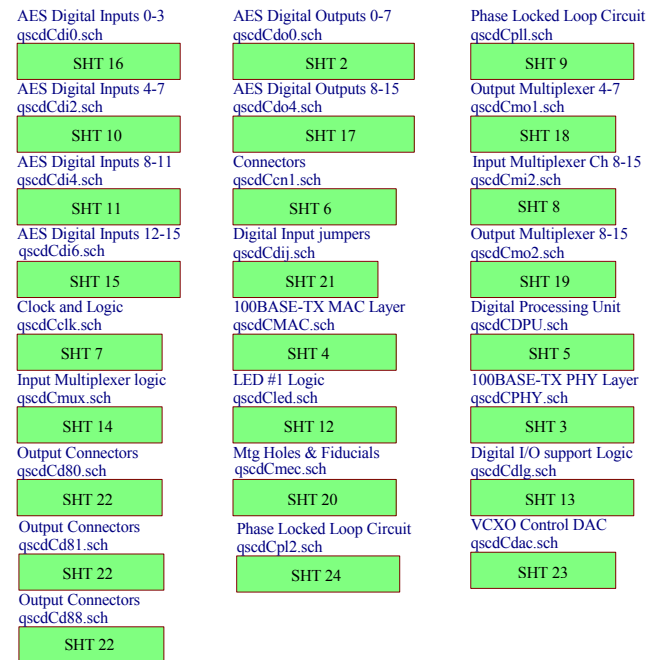

RAVE/RAPID RAVE 80 USE THE FOLLOWING SHEETS

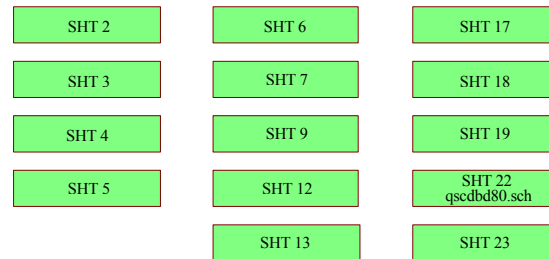

RAVE/RAPID RAVE 81 USE THE FOLLOWING SHEETS

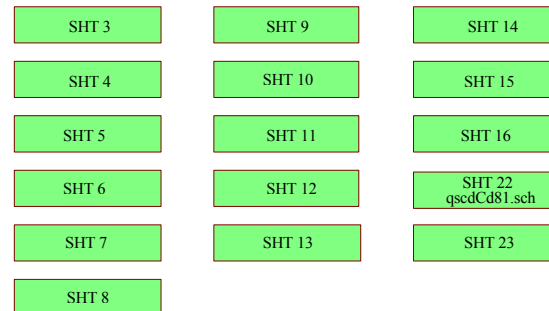

RAVE/RAPID RAVE 88 USE THE FOLLOWING SHEETS

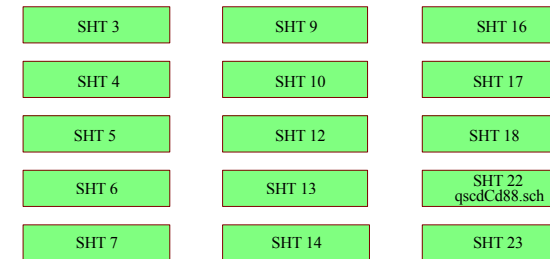

AUDIO PRODUCTS, INC.		1675 MACARTHUR BLVD. COSTA MESA, CA 92626	
Title: RAVE Digital, Block Diagram			
Size: B	Number: SH-000831-00	Rev C	
File: C:\DATA\schematics\RAVE_revB\Digital\QscdChk.DDB - Documents\QscdChk.sch			
Date: 12-Dec-2001	Eng: Karl Fitzke	Sheet 1 of 24	

THIS DOCUMENT CONTAINS PROPRIETARY INFORMATION WHICH IS THE PROPERTY OF QSC AUDIO PRODUCTS. THAT MAY NOT BE DISCLOSED, REPRODUCED OR USED WITHOUT EXPRESS WRITTEN CONSENT FROM QSC AUDIO PRODUCTS.

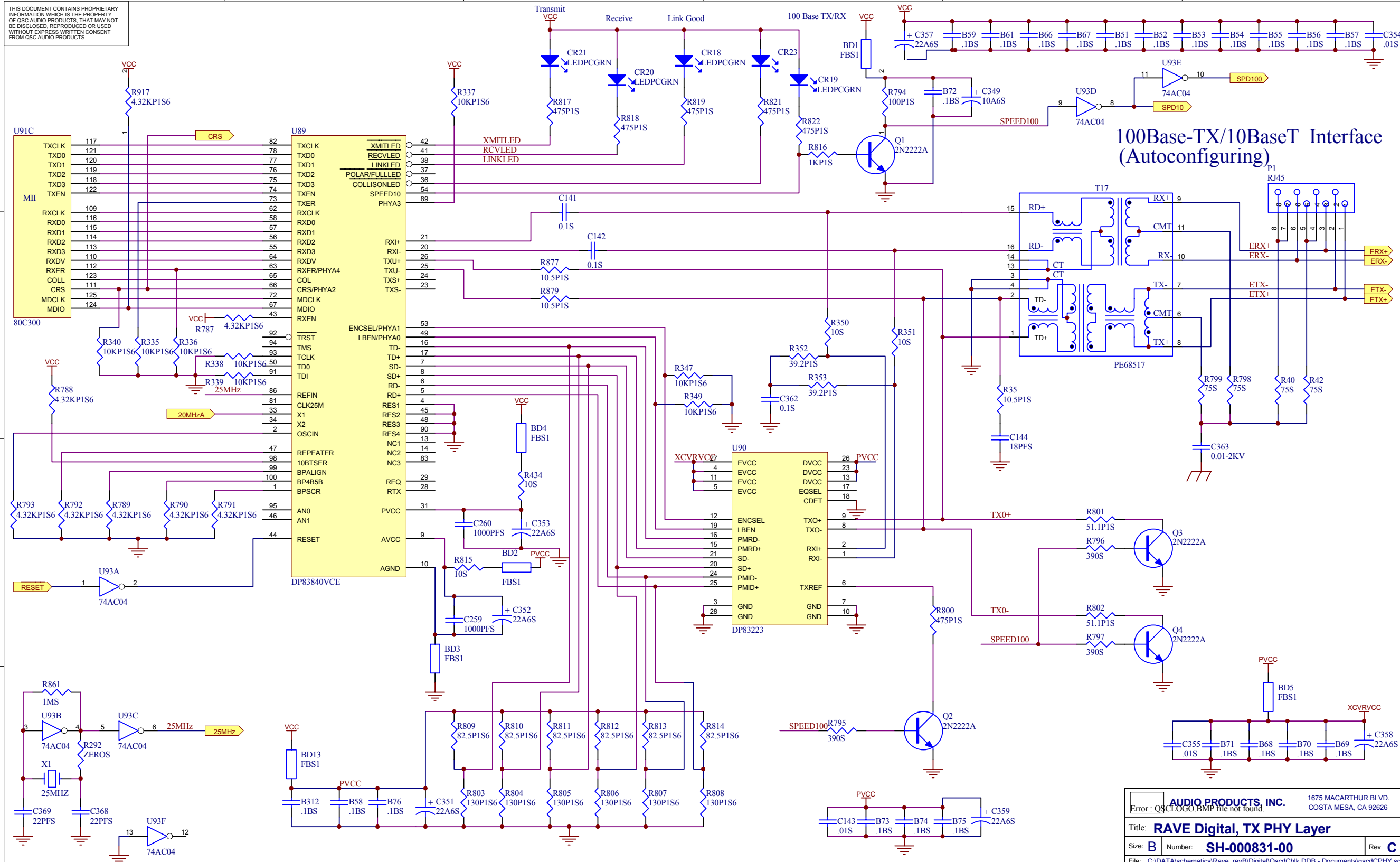

100Base-TX/10BaseT Interface (Autoconfiguring)

THIS DOCUMENT CONTAINS PROPRIETARY INFORMATION WHICH IS THE PROPERTY OF QSC AUDIO PRODUCTS. THAT MAY NOT BE DISCLOSED, REPRODUCED OR USED WITHOUT EXPRESS WRITTEN CONSENT FROM QSC AUDIO PRODUCTS.

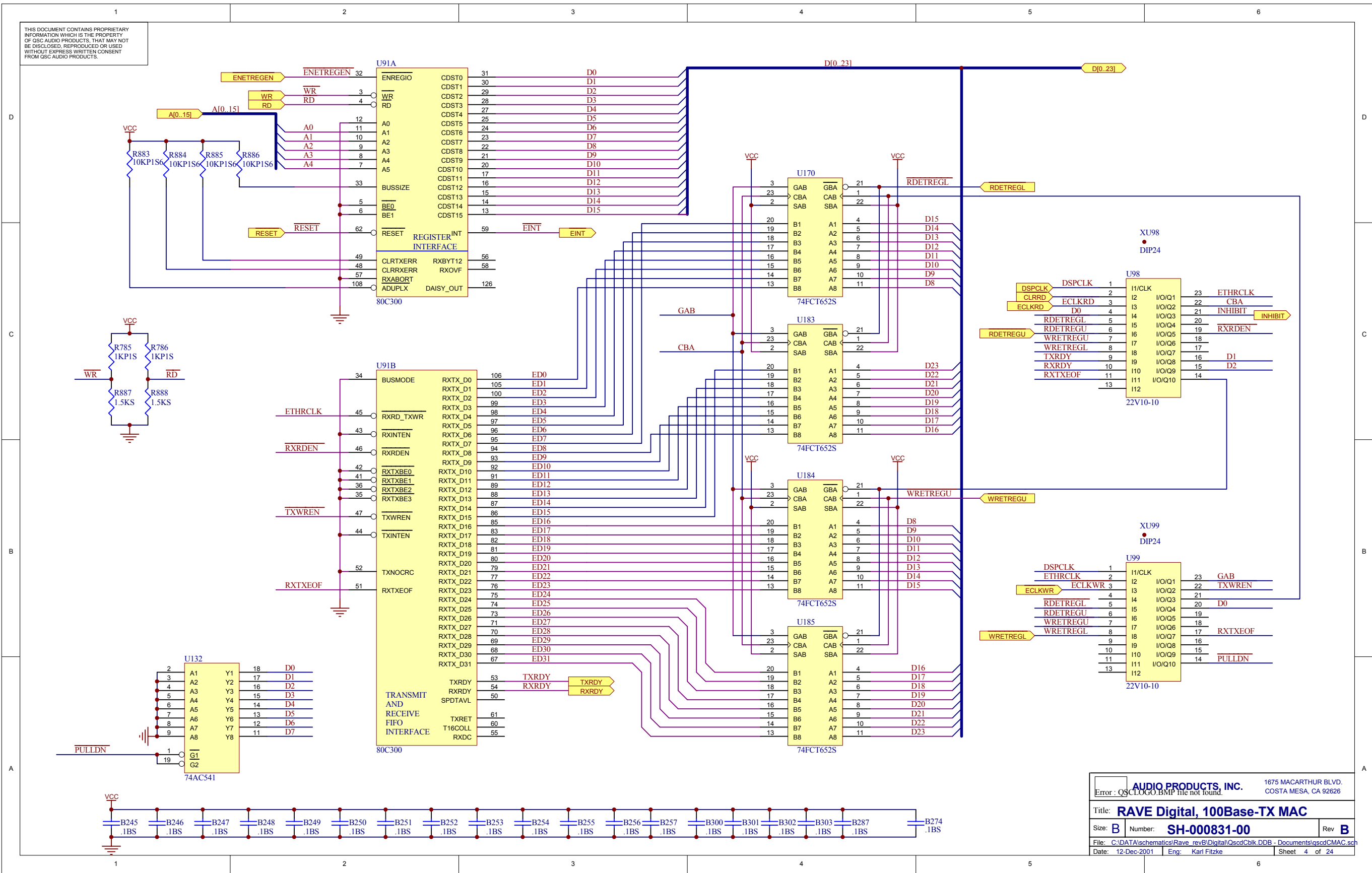

THIS DOCUMENT CONTAINS PROPRIETARY INFORMATION WHICH IS THE PROPERTY OF QSC AUDIO PRODUCTS. THAT MAY NOT BE DISCLOSED, REPRODUCED OR USED WITHOUT EXPRESS WRITTEN CONSENT FROM QSC AUDIO PRODUCTS.

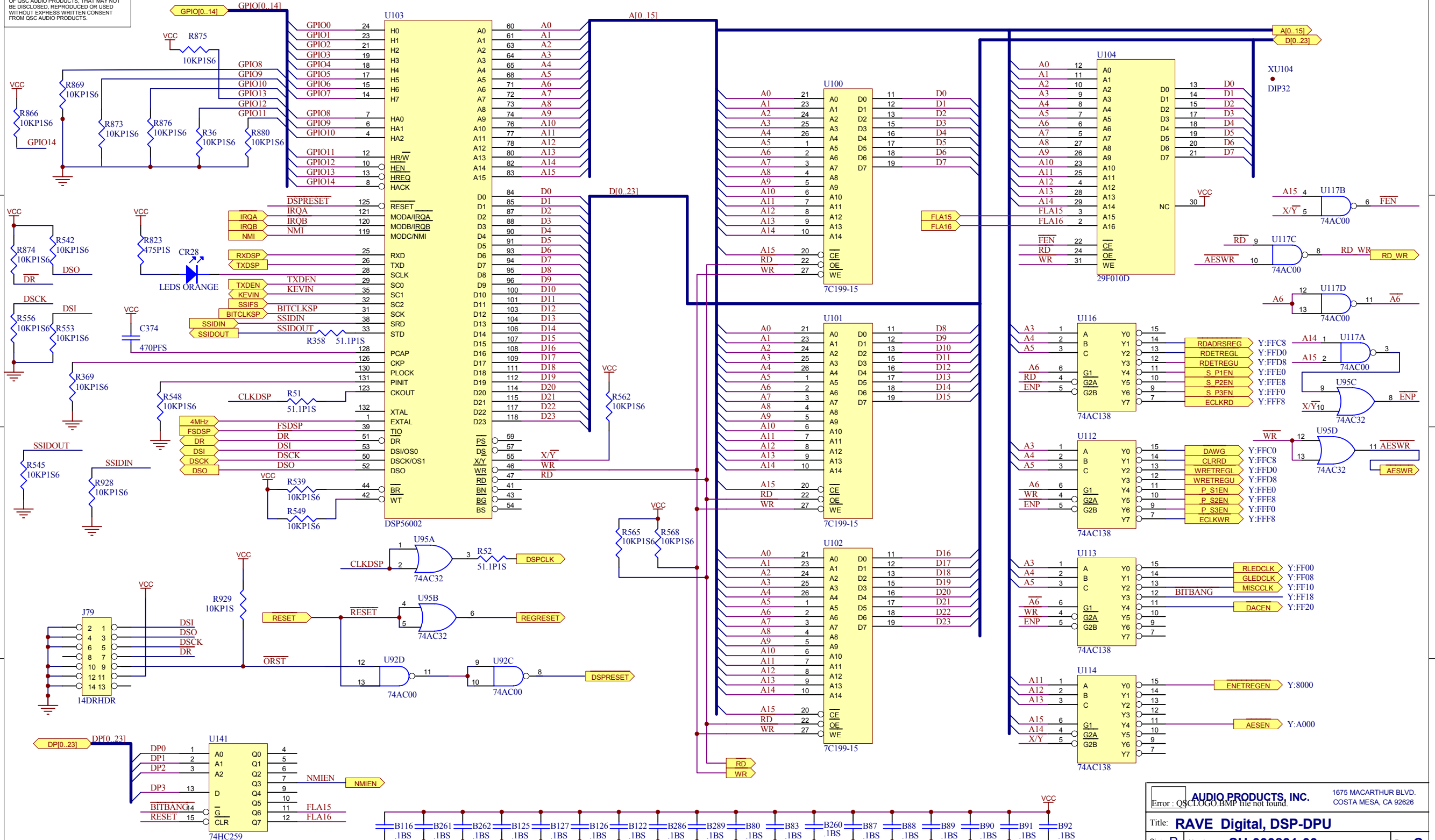

THIS DOCUMENT CONTAINS PROPRIETARY INFORMATION WHICH IS THE PROPERTY OF QSC AUDIO PRODUCTS. THAT MAY NOT BE DISCLOSED, REPRODUCED OR USED WITHOUT EXPRESS WRITTEN CONSENT FROM QSC AUDIO PRODUCTS.

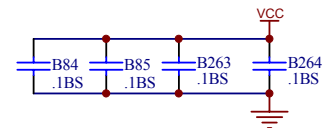
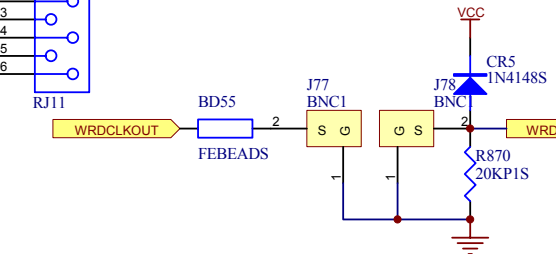
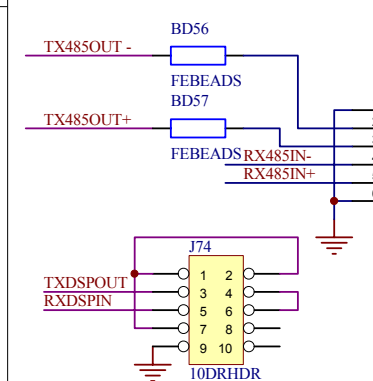
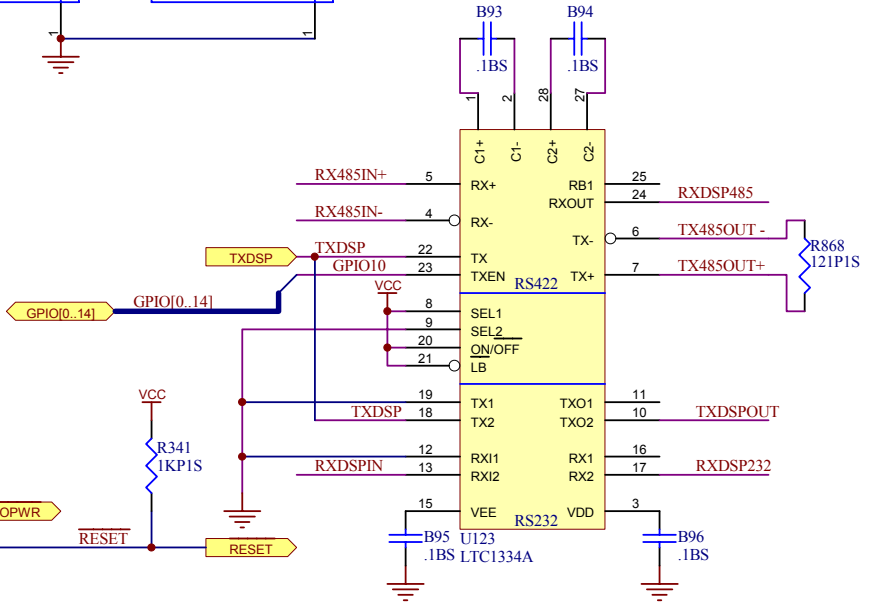
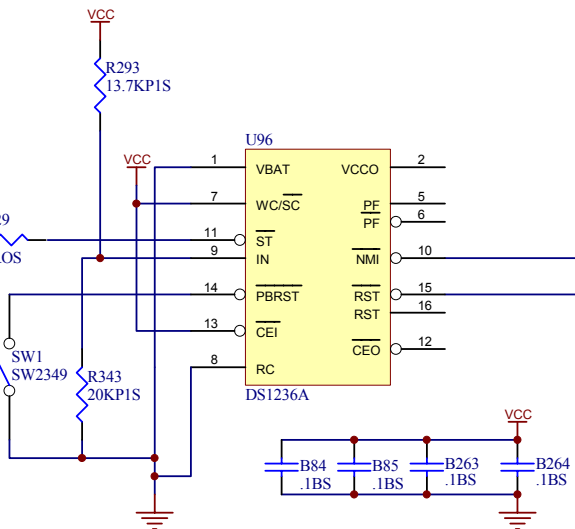
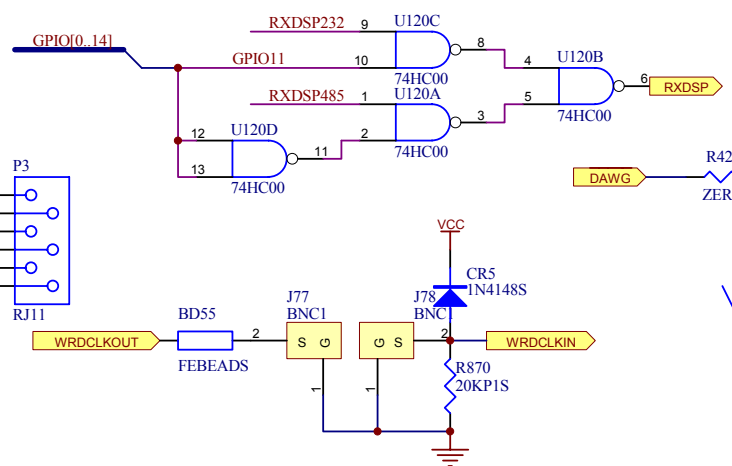
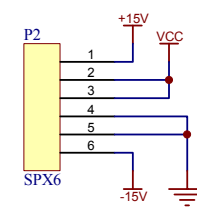
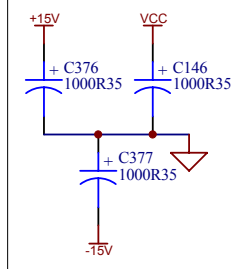
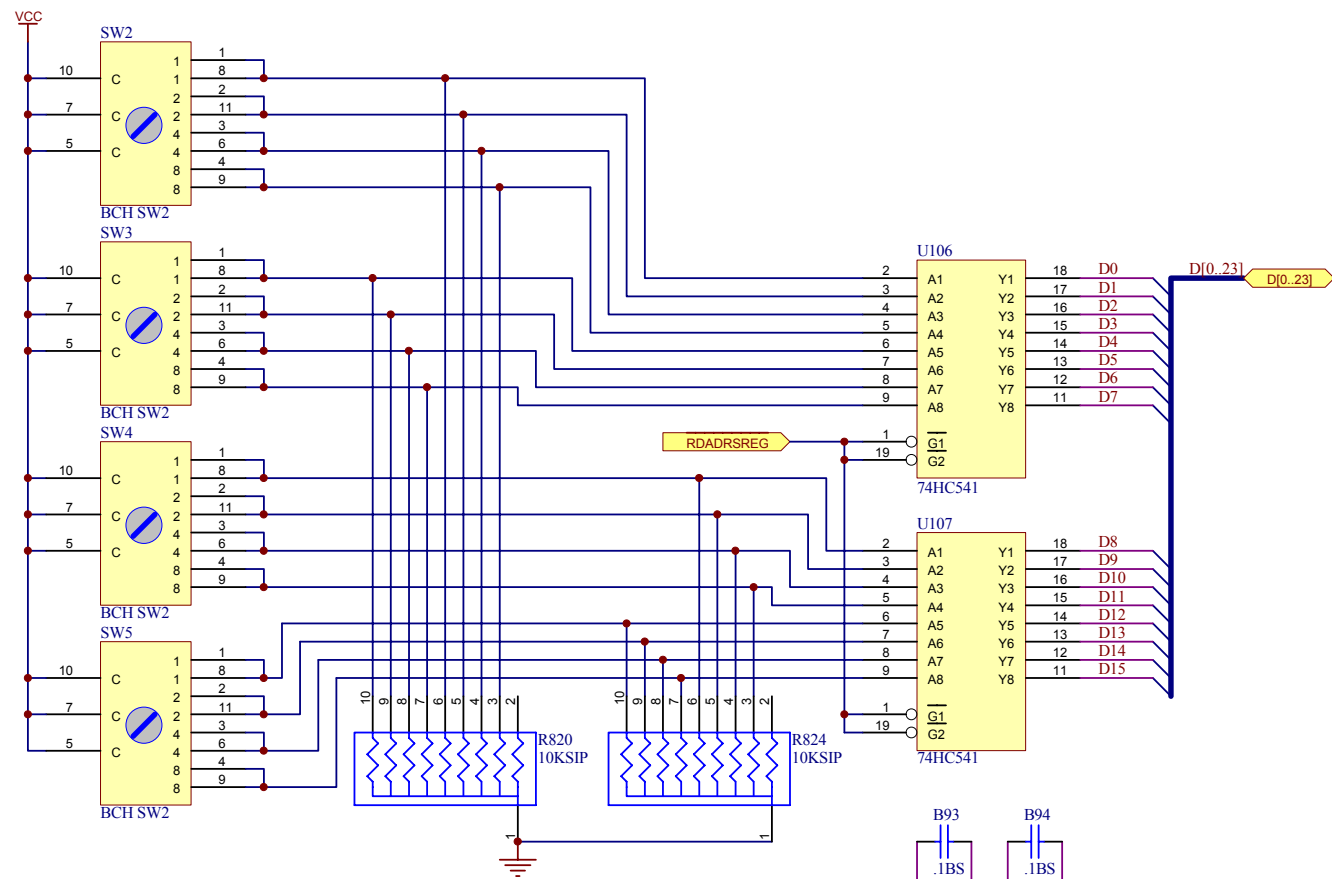
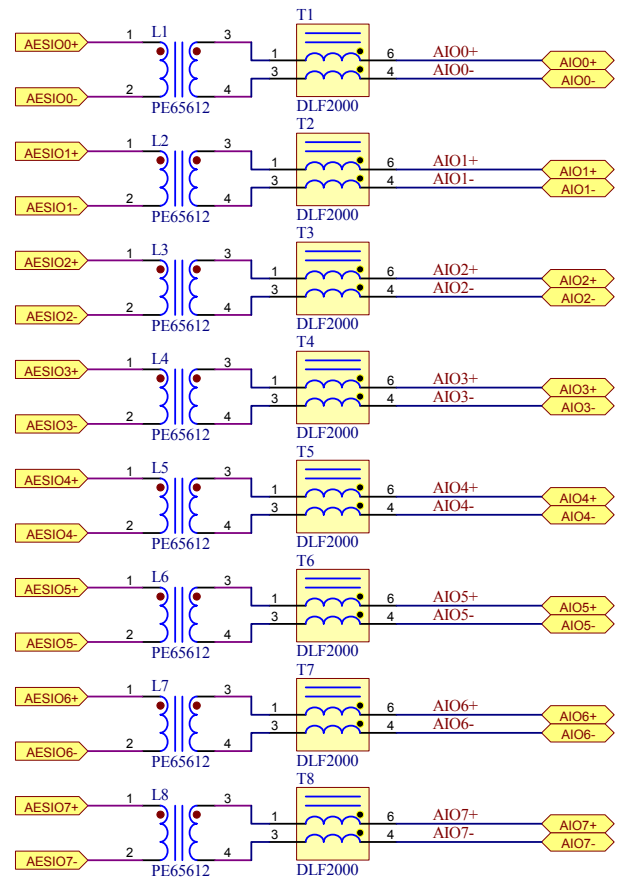

AUDIO PRODUCTS, INC. 1675 MACARTHUR BLVD. COSTA MESA, CA 92626
 Error: QSC\LOGO.BMP file not found.
 Title: **RAVE Digital, Conn & Interface**
 Size: **B** Number: **SH-000831-00** Rev: **C**
 File: C:\DATA\schematics\RAVE_revB\Digital\OscdChk.DDB - Documents\qscdCcn1.sch
 Date: 12-Dec-2001 Eng: Karl Fitzke Sheet 6 of 24

THIS DOCUMENT CONTAINS PROPRIETARY INFORMATION WHICH IS THE PROPERTY OF QSC AUDIO PRODUCTS. THAT MAY NOT BE DISCLOSED, REPRODUCED OR USED WITHOUT EXPRESS WRITTEN CONSENT FROM QSC AUDIO PRODUCTS.

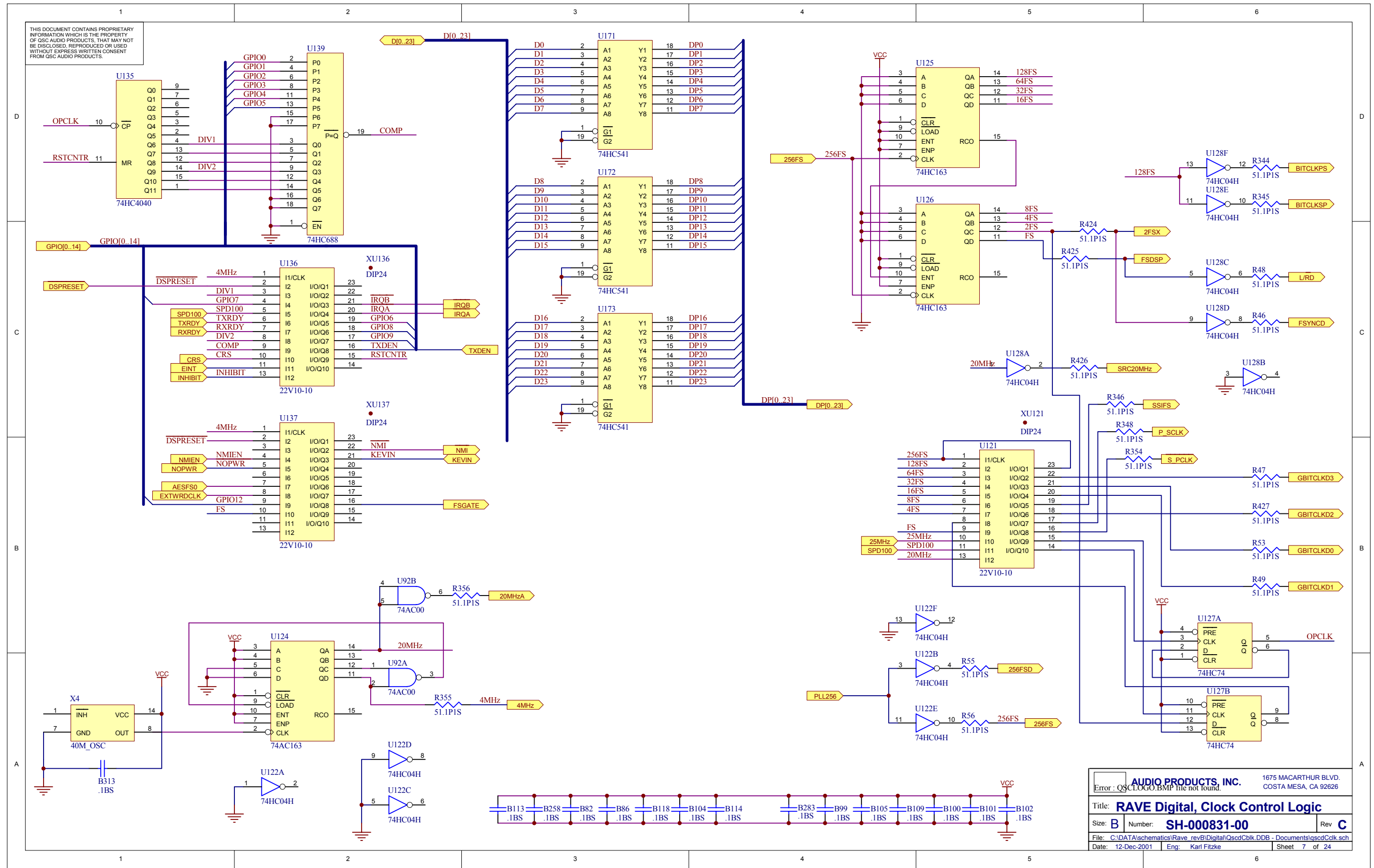

THIS DOCUMENT CONTAINS PROPRIETARY INFORMATION WHICH IS THE PROPERTY OF QSC AUDIO PRODUCTS. THAT MAY NOT BE DISCLOSED, REPRODUCED OR USED WITHOUT EXPRESS WRITTEN CONSENT FROM QSC AUDIO PRODUCTS.

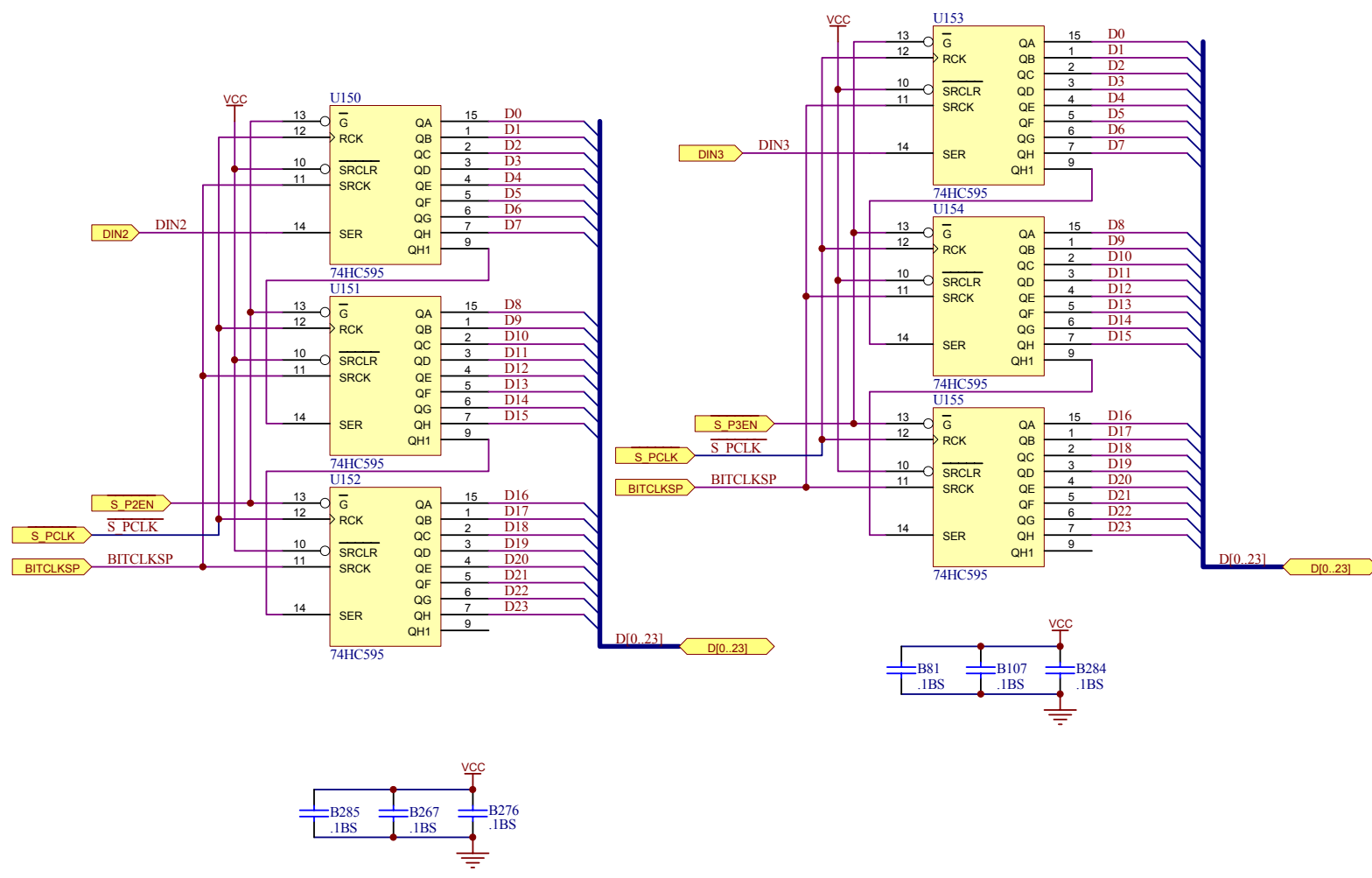

THIS DOCUMENT CONTAINS PROPRIETARY INFORMATION WHICH IS THE PROPERTY OF QSC AUDIO PRODUCTS. THAT MAY NOT BE DISCLOSED, REPRODUCED OR USED WITHOUT EXPRESS WRITTEN CONSENT FROM QSC AUDIO PRODUCTS.

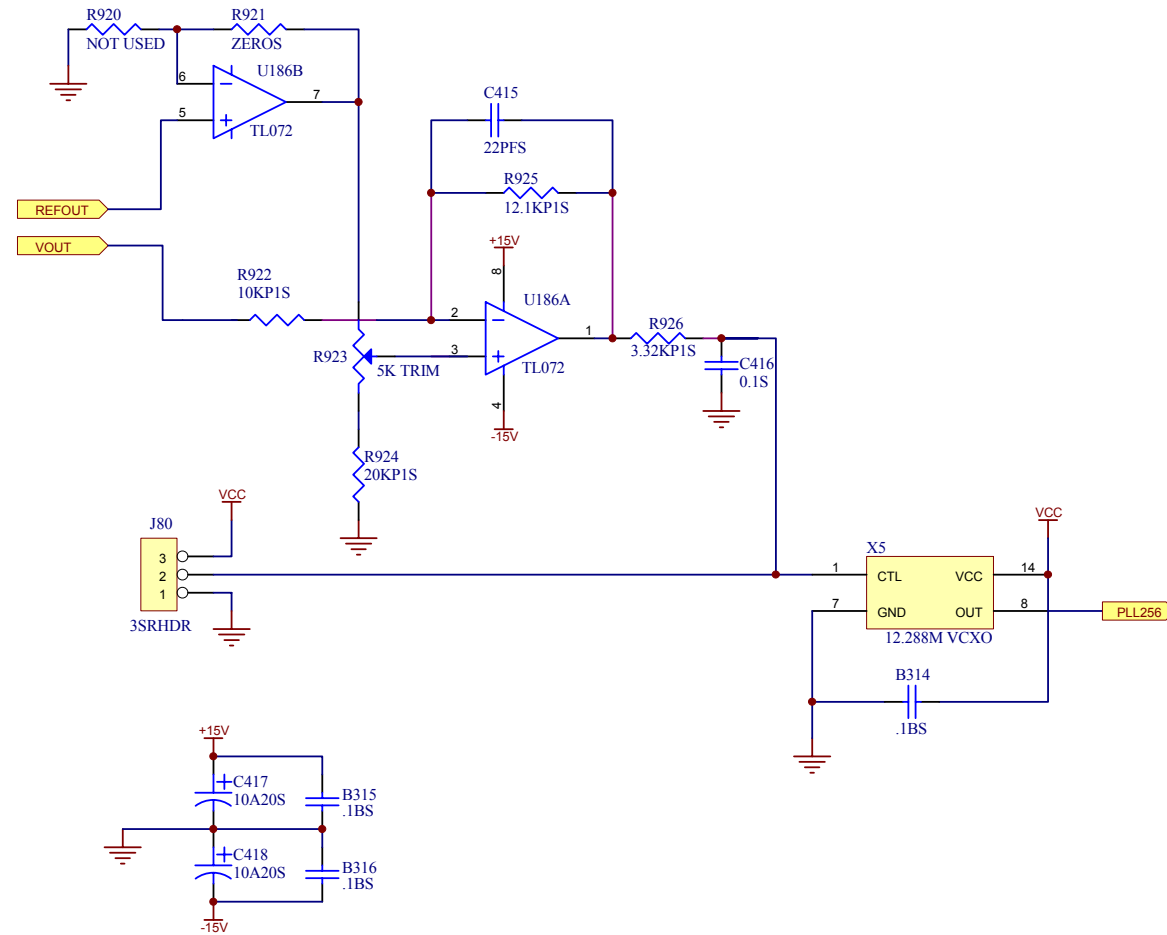

THIS DOCUMENT CONTAINS PROPRIETARY INFORMATION WHICH IS THE PROPERTY OF QSC AUDIO PRODUCTS. THAT MAY NOT BE DISCLOSED, REPRODUCED OR USED WITHOUT EXPRESS WRITTEN CONSENT FROM QSC AUDIO PRODUCTS.

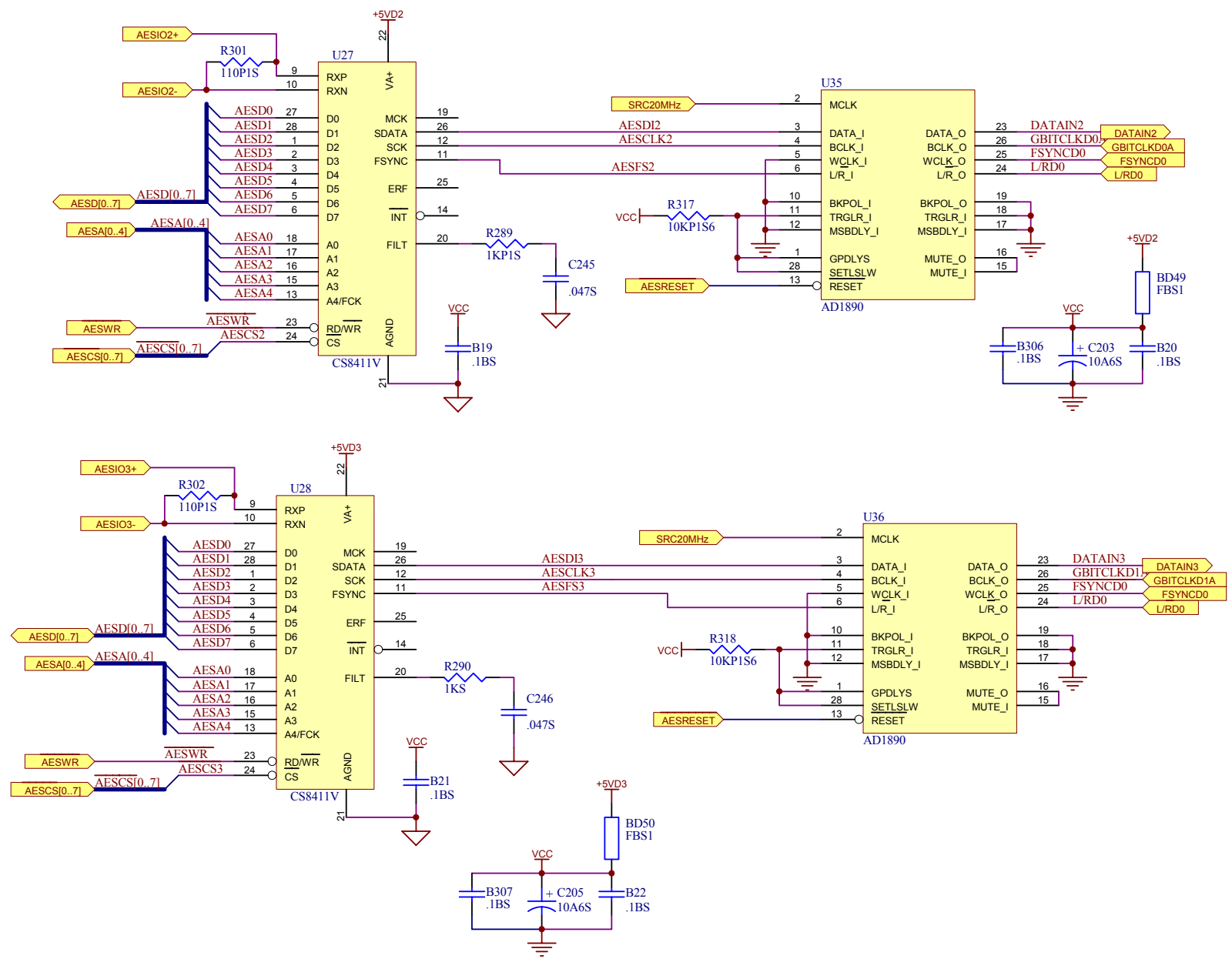

THIS DOCUMENT CONTAINS PROPRIETARY INFORMATION WHICH IS THE PROPERTY OF QSC AUDIO PRODUCTS. THAT MAY NOT BE DISCLOSED, REPRODUCED OR USED WITHOUT EXPRESS WRITTEN CONSENT FROM QSC AUDIO PRODUCTS.

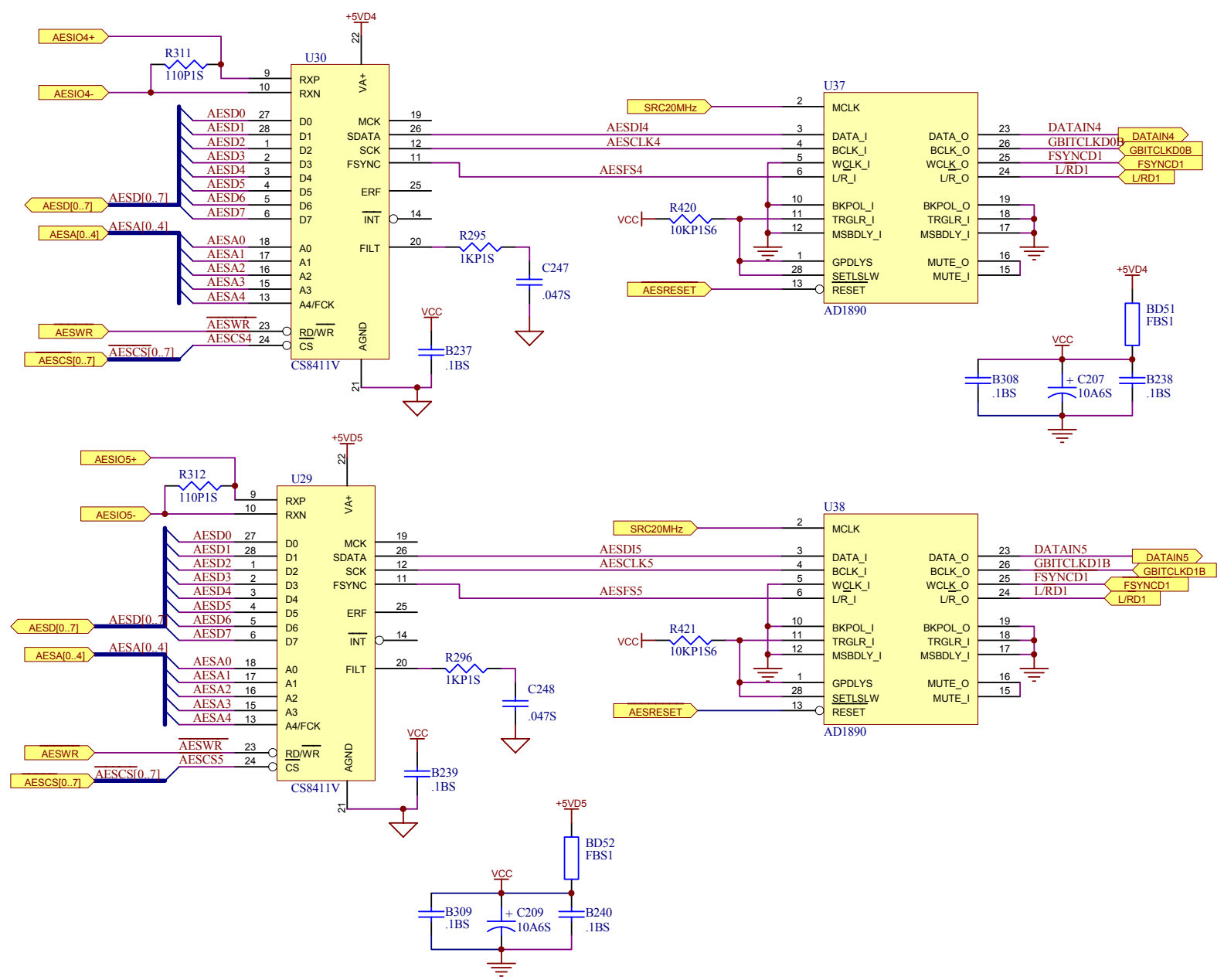

THIS DOCUMENT CONTAINS PROPRIETARY INFORMATION WHICH IS THE PROPERTY OF QSC AUDIO PRODUCTS. THAT MAY NOT BE DISCLOSED, REPRODUCED OR USED WITHOUT EXPRESS WRITTEN CONSENT FROM QSC AUDIO PRODUCTS.

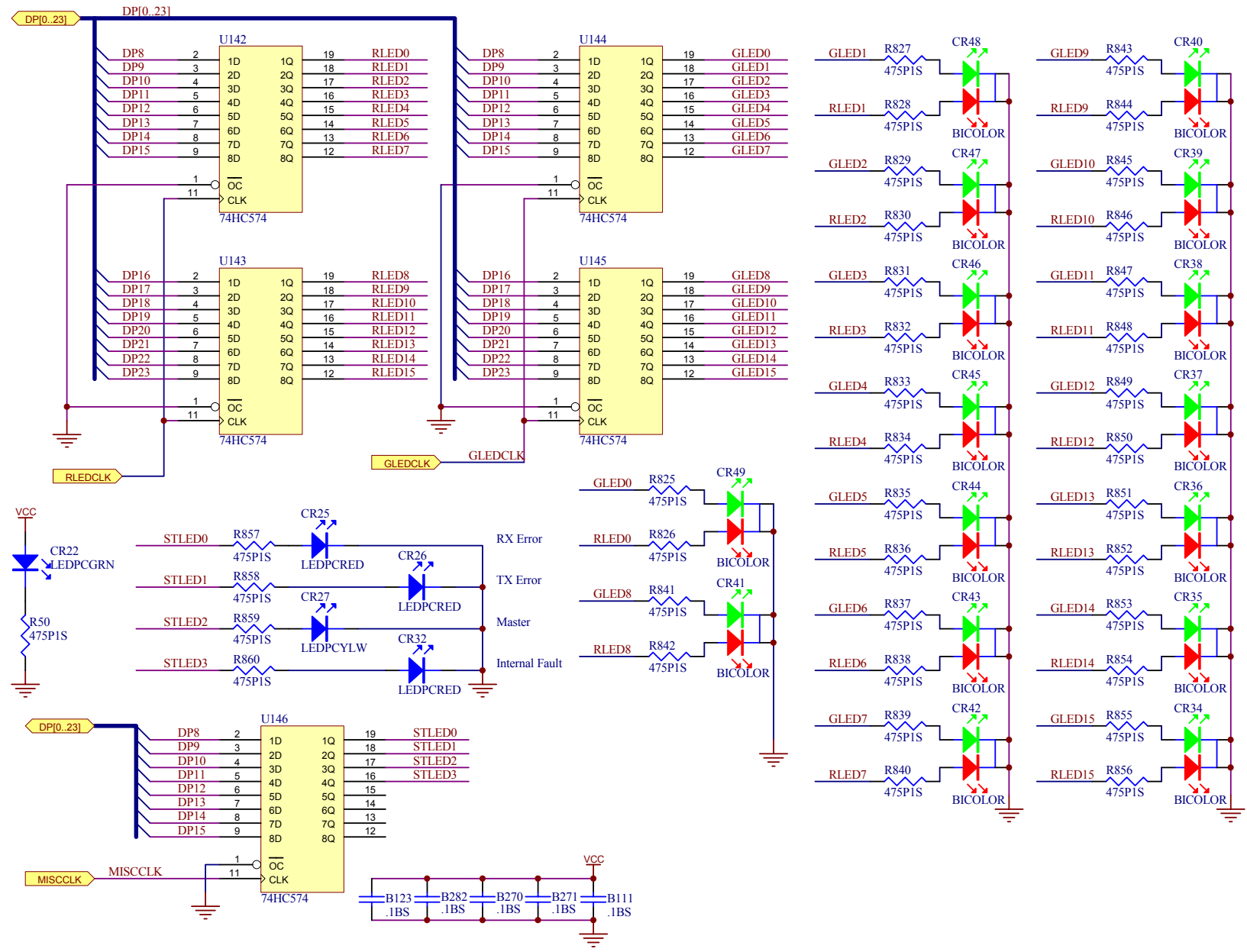

THIS DOCUMENT CONTAINS PROPRIETARY INFORMATION WHICH IS THE PROPERTY OF QSC AUDIO PRODUCTS. THAT MAY NOT BE DISCLOSED, REPRODUCED OR USED WITHOUT EXPRESS WRITTEN CONSENT FROM QSC AUDIO PRODUCTS.

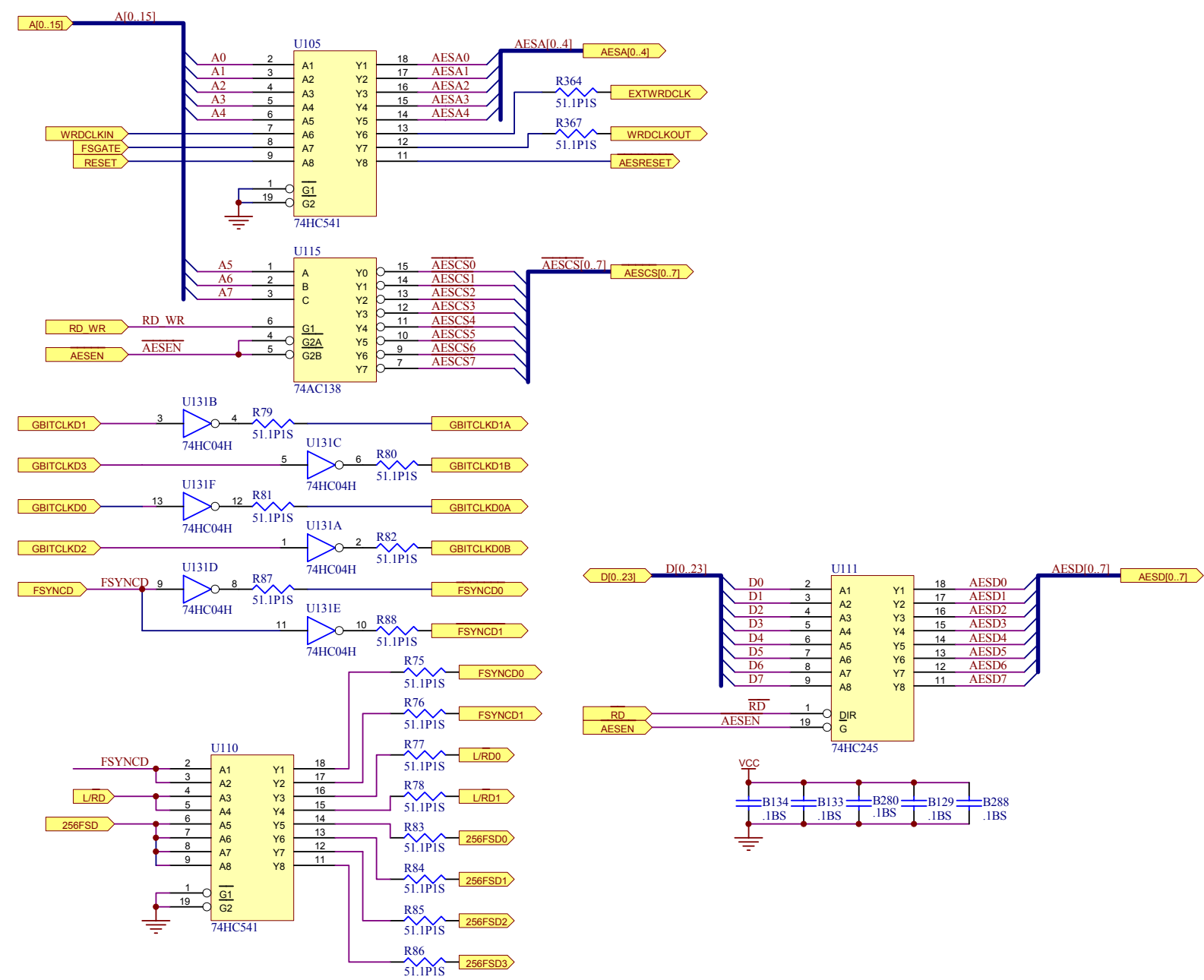

THIS DOCUMENT CONTAINS PROPRIETARY INFORMATION WHICH IS THE PROPERTY OF QSC AUDIO PRODUCTS. THAT MAY NOT BE DISCLOSED, REPRODUCED OR USED WITHOUT EXPRESS WRITTEN CONSENT FROM QSC AUDIO PRODUCTS.

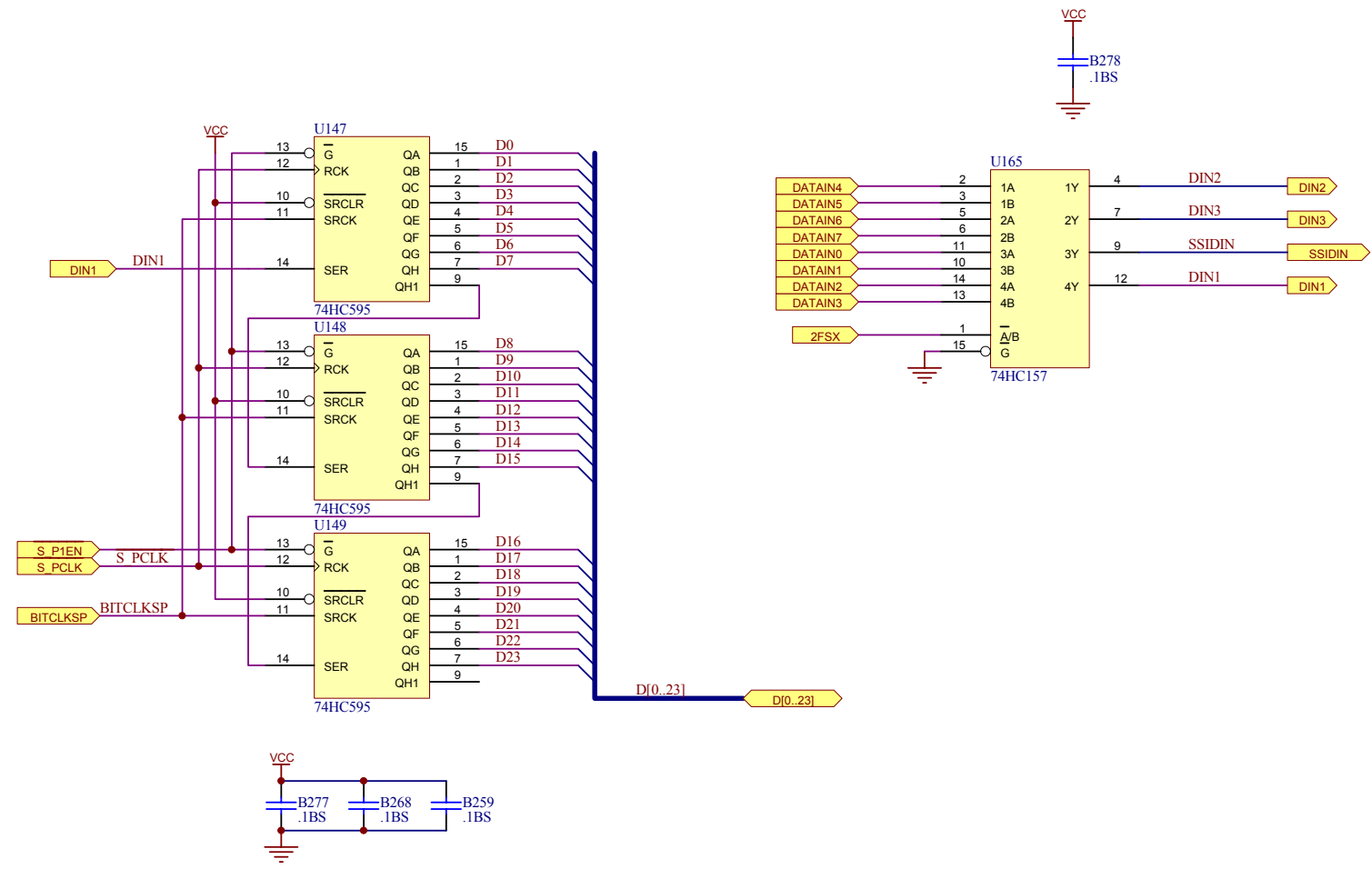

THIS DOCUMENT CONTAINS PROPRIETARY INFORMATION WHICH IS THE PROPERTY OF QSC AUDIO PRODUCTS. THAT MAY NOT BE DISCLOSED, REPRODUCED OR USED WITHOUT EXPRESS WRITTEN CONSENT FROM QSC AUDIO PRODUCTS.

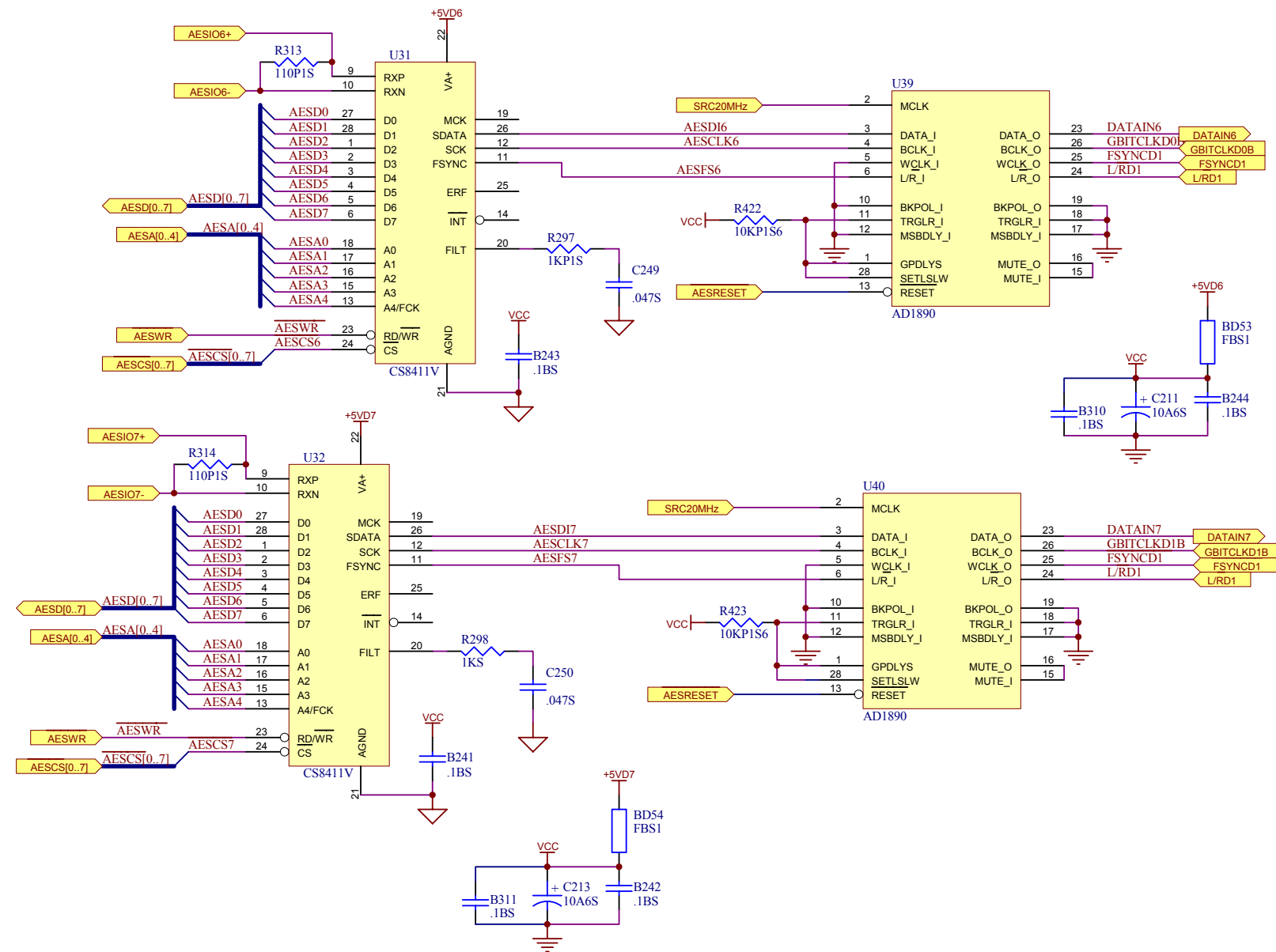

THIS DOCUMENT CONTAINS PROPRIETARY INFORMATION WHICH IS THE PROPERTY OF QSC AUDIO PRODUCTS. THAT MAY NOT BE DISCLOSED, REPRODUCED OR USED WITHOUT EXPRESS WRITTEN CONSENT FROM QSC AUDIO PRODUCTS.

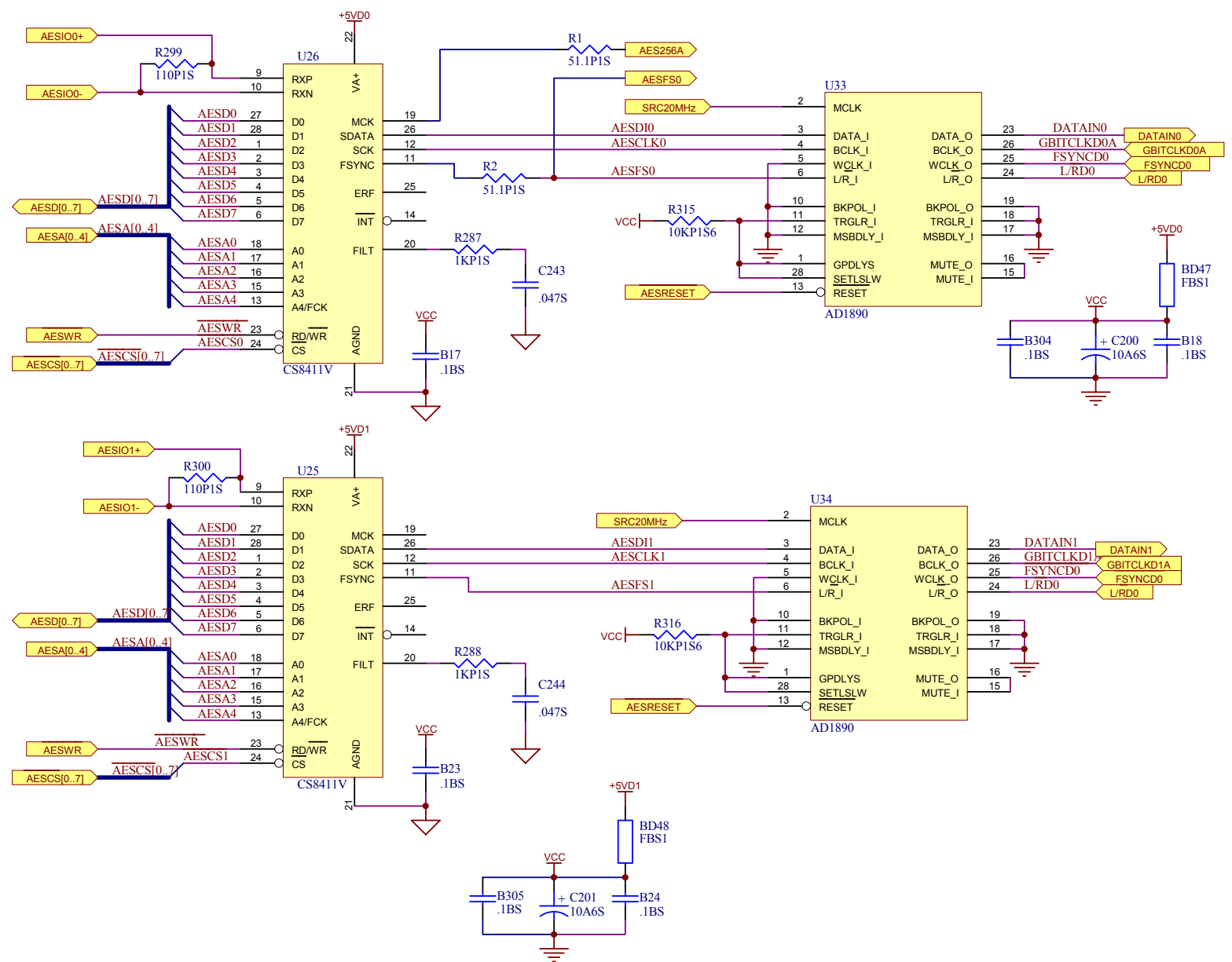

THIS DOCUMENT CONTAINS PROPRIETARY INFORMATION WHICH IS THE PROPERTY OF QSC AUDIO PRODUCTS. THAT MAY NOT BE DISCLOSED, REPRODUCED OR USED WITHOUT EXPRESS WRITTEN CONSENT FROM QSC AUDIO PRODUCTS.

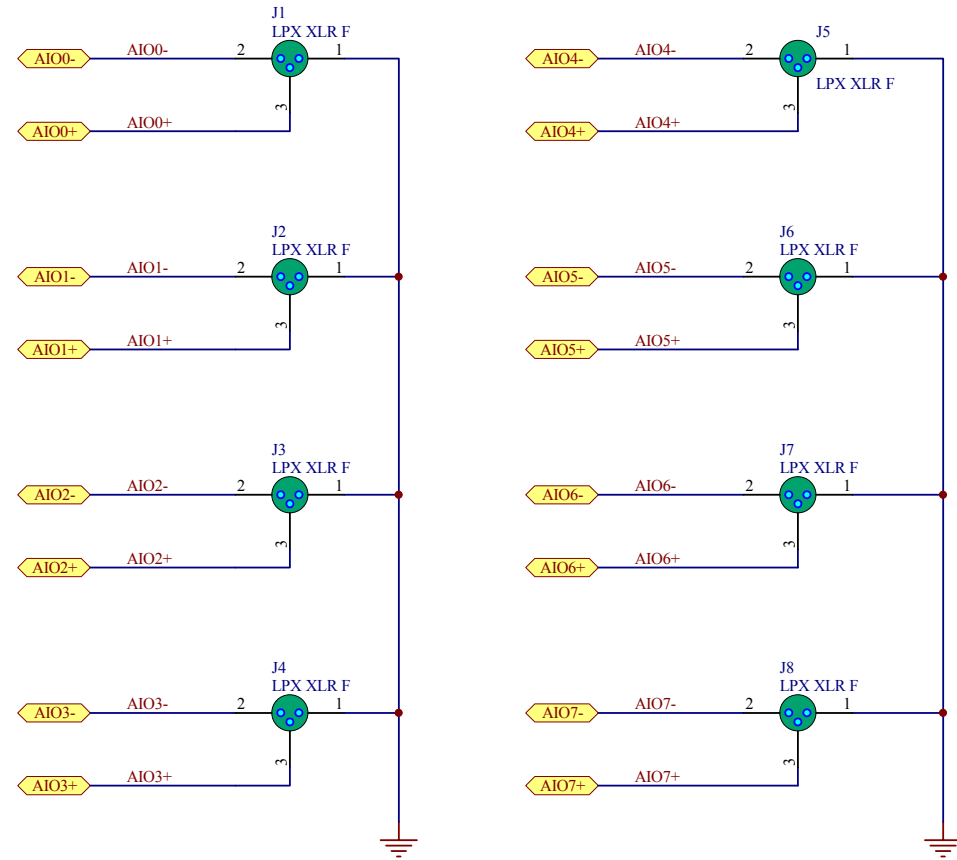

AUDIO PRODUCTS, INC. 1675 MACARTHUR BLVD.
 COSTA MESA, CA 92626
 Error: QSC\LOGO.BMP file not found.
 Title: **RAVE Digital, RAVE 81 Connectors**
 Size: B Number: **SH-000831-00** Rev **C**
 File: C:\DATA\schematics\RAve_revB\Digital\QscdCblk.DDB - Documents\qscdCd81.sch
 Date: 12-Dec-2001 Eng: Karl Fitzke Sheet 22 of 24

THIS DOCUMENT CONTAINS PROPRIETARY INFORMATION WHICH IS THE PROPERTY OF QSC AUDIO PRODUCTS. THAT MAY NOT BE DISCLOSED, REPRODUCED OR USED WITHOUT EXPRESS WRITTEN CONSENT FROM QSC AUDIO PRODUCTS.

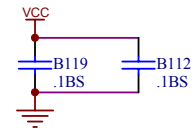
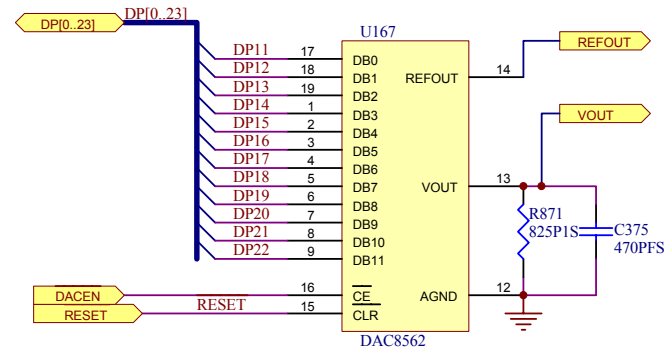

AUDIO PRODUCTS, INC.		1675 MACARTHUR BLVD. COSTA MESA, CA 92626	
Title: RAVE Digital, PLL / VCXO			
Size: B	Number: SH-000831-00	Rev: C	
File: C:\DATA\schematics\RAVE_revB\Digital\OscdChk.DDB - Documents\qscdCdac.sch			
Date: 12-Dec-2001	Eng: Karl Fitzke	Sheet 23 of 24	