

THIS DOCUMENT CONTAINS PROPRIETARY INFORMATION WHICH IS THE PROPERTY OF QSC AUDIO PRODUCTS, THAT MAY NOT BE DISCLOSED, REPRODUCED OR USED WITHOUT EXPRESS WRITTEN CONSENT FROM QSC AUDIO PRODUCTS.

REVISION				
REV	DESCRIPTION	EFF. DATE	CHK	APPROVED / DATE
A	PRODUCTION RELEASE PER ECO 4345 AA	7-19-00		

**PL2A CONFIGURATION SWITCH TABLE  
SW 9--(VMON, IMON)-----**

MODEL	VmonA			ImonA		VmonB			ImonB	
	1	2	3	4	5	6	7	8	9	10
PL218A	1	1	0	0	1	1	1	0	0	1
PL224A	0	0	1	1	1	0	0	1	1	1
PL230A	0	0	1	1	0	0	0	1	1	0
PL236A	1	1	1	0	0	1	1	1	0	0

**SW 5--(GAIN, IDR)-----**

Gain ch A			Gain ch B			IDR -----			
1	2	3	4	5	6	7	8	9	10
1	1	1	1	1	1	1	1	1	0
1	0	1	1	0	1	1	0	1	1
0	0	1	0	0	1	1	0	0	1
1	1	0	1	1	0	0	1	0	0

NOTES:  
THIS TABLE IS SHOWN AS IF YOU ARE LOOKING AT THE SWITCHES FROM ABOVE IN THE CHASSIS (FRONT CORNER).

2. COMPONENTS WITH VALUE PREFIXED WITH A "\*" REPRESENT SMT COMPONENTS.  
1. THIS DRAWING USED IN CONJUNCTION WITH ASSEMBLY WP-001809-00.  
NOTES: UNLESS OTHERWISE SPECIFIED

QTY	ITEM NO.	PART NO.	DESCRIPTION	VENDOR
<b>PARTS LIST</b>				
UNLESS OTHERWISE SPECIFIED DIMENSIONS ARE IN INCHES. DIMENSIONS PER ANSI Y14.5-1982 TOLERANCES ARE: DECIMALS    DECIMALS    ANGLES .xx ±        .xxx ±        0			CONTRACT NO.	
DEBURR EDGES .XXX R MAX MATERIAL			APPROVALS    DATE	
FINISH			DRAWN    Pat Quilter    3-20-00	
NEXT ASSY    USED ON			CHECKED	
APPLICATION			ISSUED	
DO NOT SCALE DRAWING			CAD SEED FILE NO.    PLOT DATE: Thu Jan 31, 2002	
WP-001809-00    PL2A		FSCM NO.		REV    A
SCALE    NONE		DWG NO.    SH-001809-00		SIZE    D
CAD FILE NO.    SH1809A.sch		SHEET    1 OF 3		REV    A

**QSC AUDIO PRODUCTS, INC.**  
COSTA MESA, CALIFORNIA

**SCHEMATIC DIAGRAM  
PL2A ANALOG PROCESSOR**

A REV 1 SH-001809-00

THIS DOCUMENT CONTAINS PROPRIETARY INFORMATION WHICH IS THE PROPERTY OF QSC AUDIO PRODUCTS, THAT MAY NOT BE DISCLOSED, REPRODUCED OR USED WITHOUT EXPRESS WRITTEN CONSENT FROM QSC AUDIO PRODUCTS.

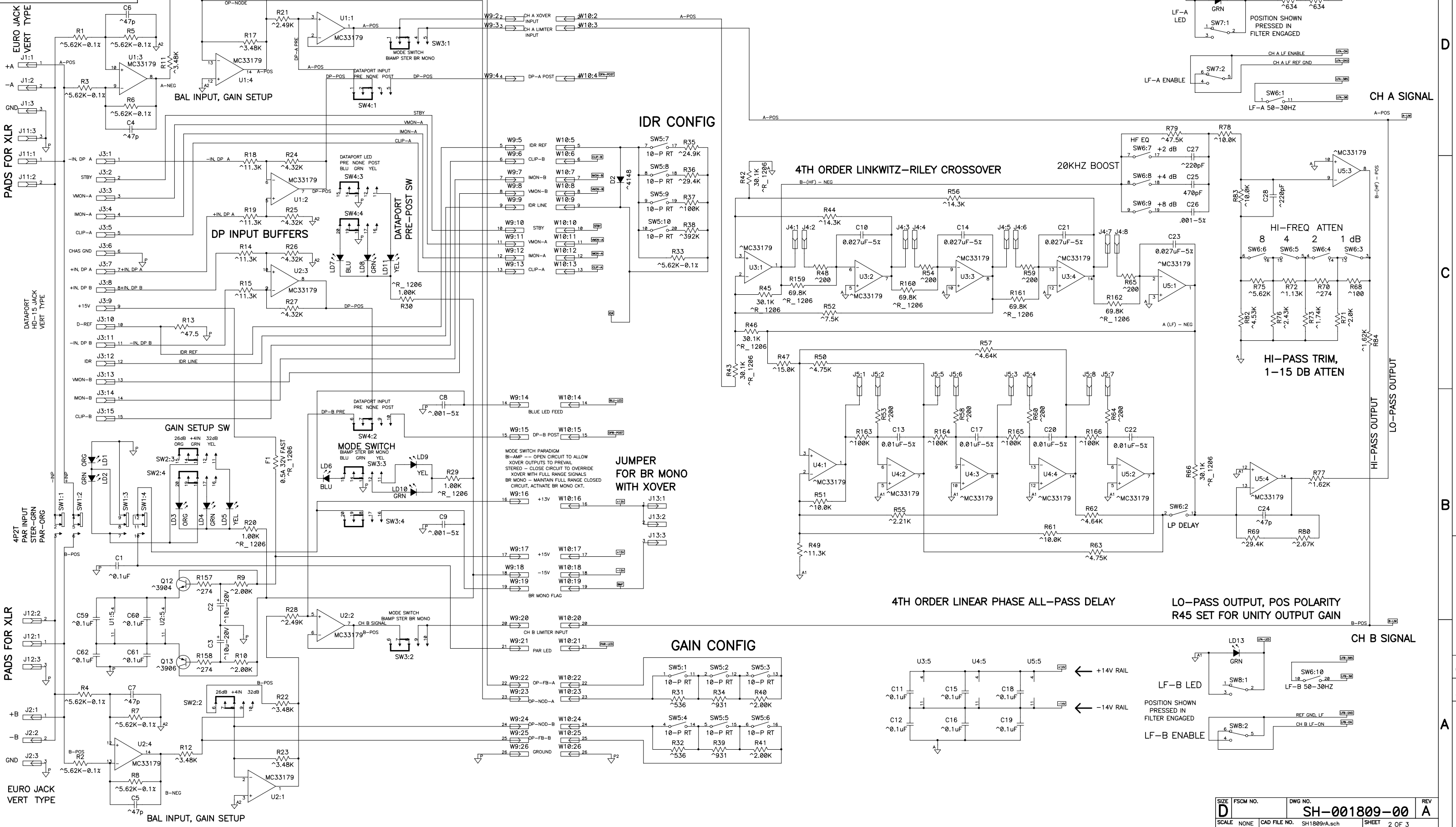

8  
7  
6  
5  
4  
3  
2  
1

D  
C  
B  
A

8 7 6 5 4 3 2 1

SIZE <b>D</b>	FSCM NO.	DWG NO. <b>SH-001809-00</b>	REV <b>A</b>
SCALE NONE	CAD FILE NO. SH1809A.sch	SHEET 2 OF 3	

THIS DOCUMENT CONTAINS PROPRIETARY INFORMATION WHICH IS THE PROPERTY OF QSC AUDIO PRODUCTS, THAT MAY NOT BE DISCLOSED, REPRODUCED OR USED WITHOUT EXPRESS WRITTEN CONSENT FROM QSC AUDIO PRODUCTS.

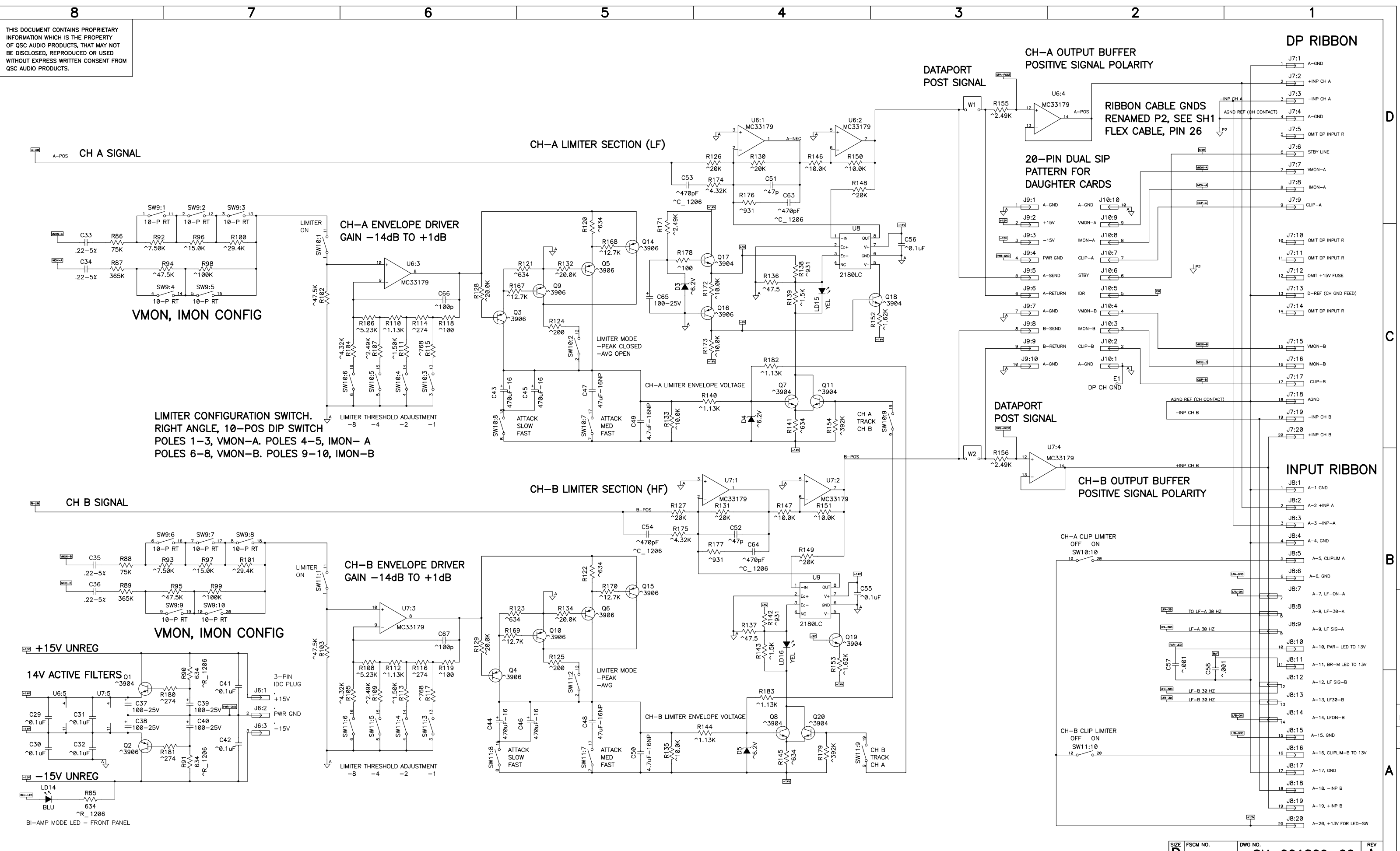

A 3 SH-001809-00