

THIS DOCUMENT CONTAINS PROPRIETARY INFORMATION
 WHICH IS THE PROPERTY OF QSC AUDIO PRODUCTS, LLC.
 MAY NOT BE DISCLOSED, REPRODUCED OR USED WITHOUT
 EXPRESS WRITTEN CONSENT FROM QSC AUDIO PRODUCTS.

REVISIONS					
REV	ECO	DESCRIPTION	BY	EFF DATE	ISSUED
10	-	REDESIGN	RS	05-APR-10	-
A	9991	PRODUCTION REL. W. CHANGE, REV NOTES & ADD ITEM 27	RS	26-MAY-10	DD

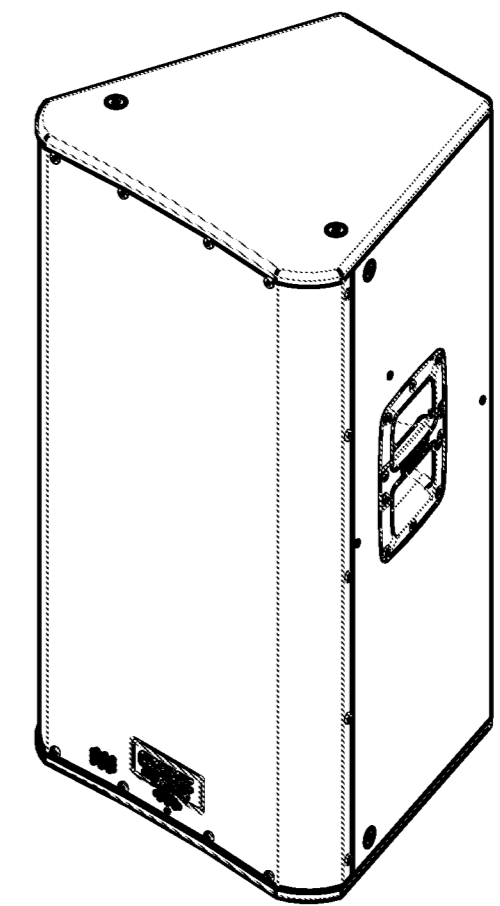
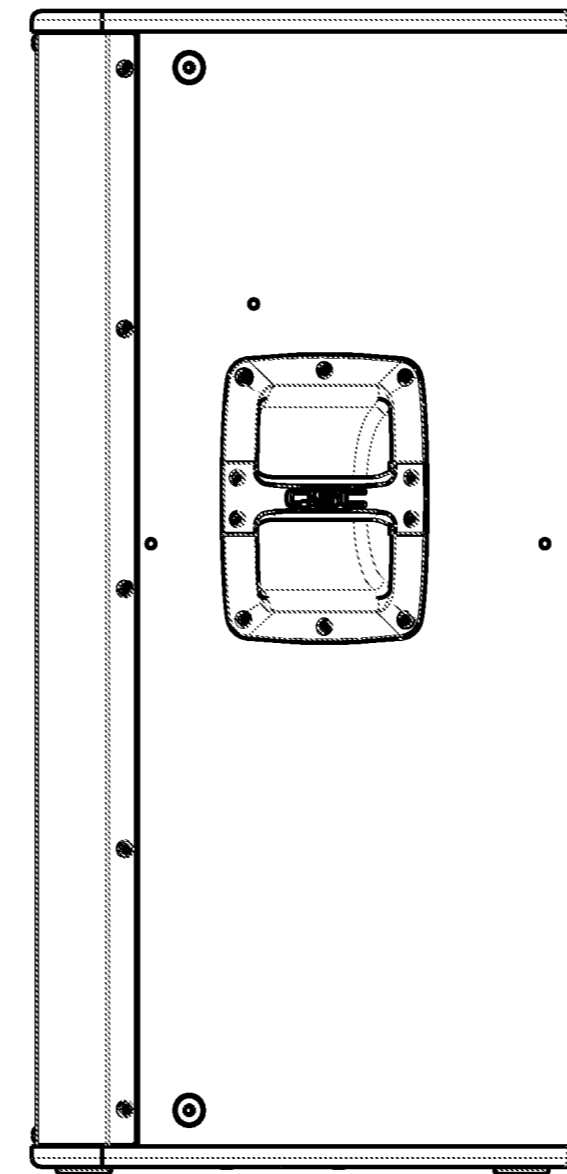
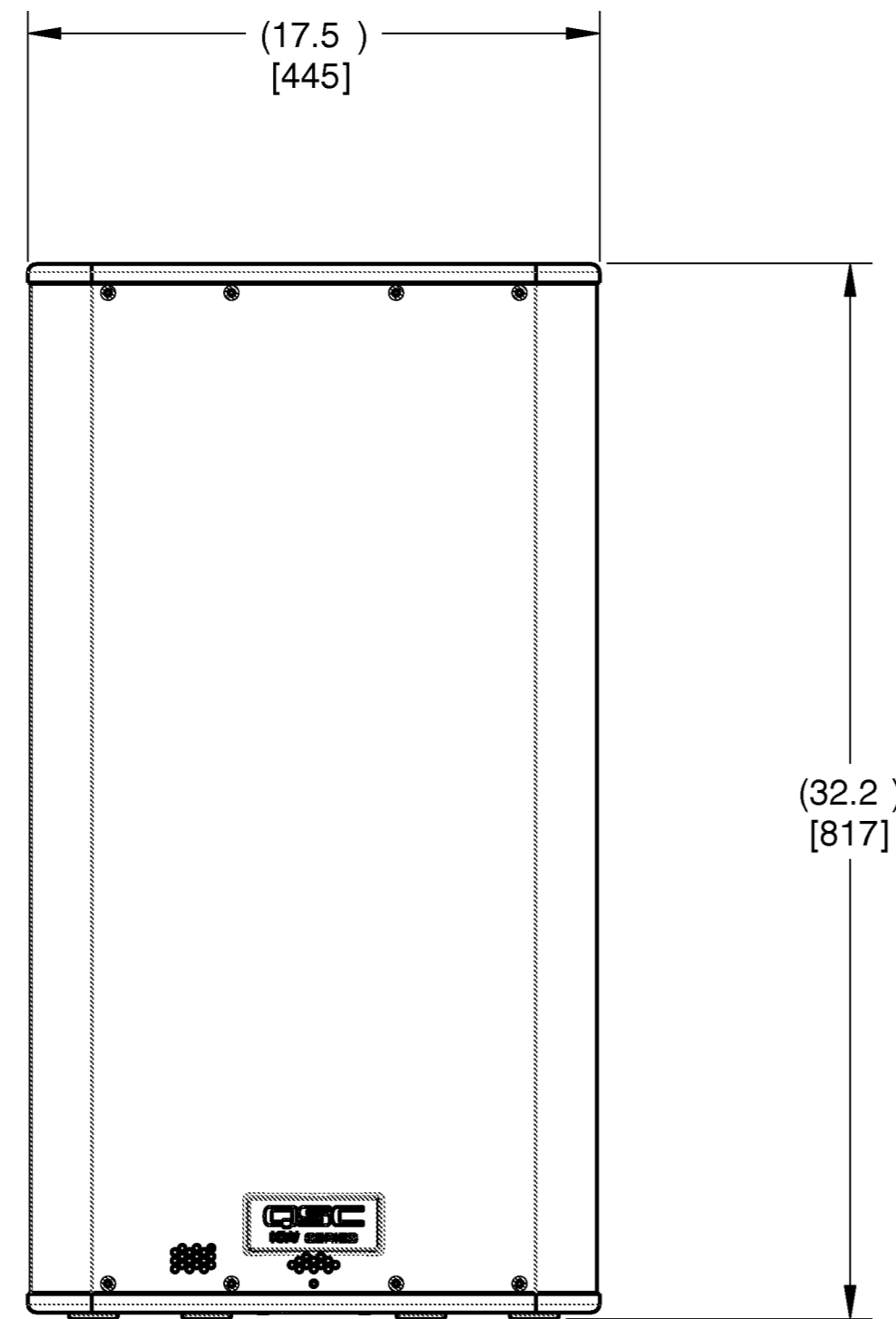
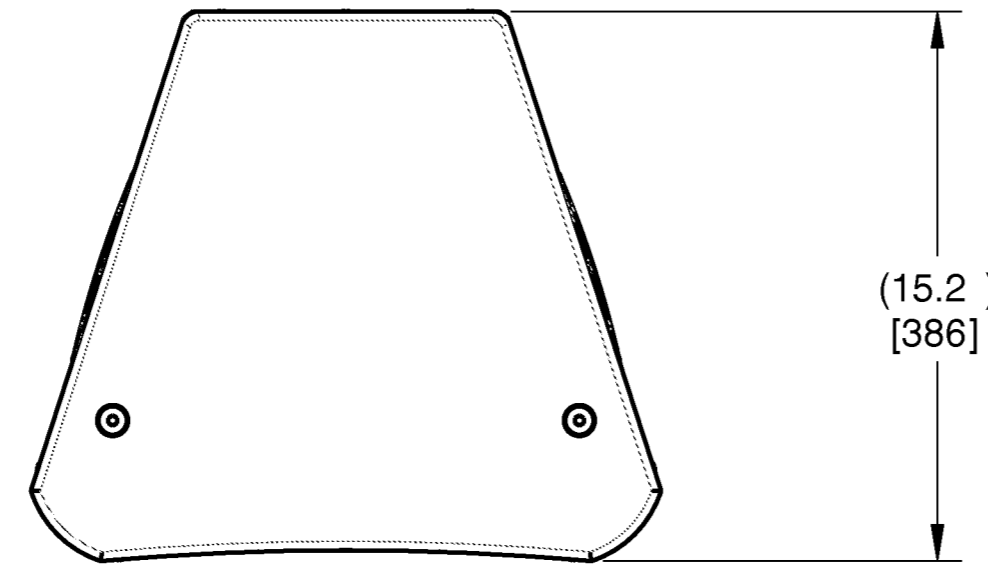

SCALE 0.125

- 7 ENSURE PROPER SEATING OF HARDWARE AND TORQUE TO 40 lb-in.
- 6 ENSURE PROPER SEATING OF HARDWARE AND TORQUE TO 25 lb-in.
- 5 APPLY 1/2 X 1/2 GASKET (PS-000168-00) ON ENCLOSURE AT HORN AND HANDLE CUP MATINGS SURFACES PRIOR TO INSTALLATION.
- 4 APPLY 1/2 X 1/8 GASKET (PS-000128-00) ON ENCLOSURE AT MATING SURFACES PRIOR TO INSTALLATION.
- 3 APPLY 1/4 X 1/8 GASKET (PS-000130-00) ON MATING SURFACES PRIOR TO INSTALLATION.

2. ALL DIMENSIONS NOT SHOWN ARE DERIVED FROM CONTROLLED DATA FILE: <DWG NO.> <CURRENT REV.>
 1. THIS PART MUST BE ROHS COMPLIANT PER QSC RD-000160-00. SUPPLIER TO PROVIDE A CERTIFICATE OF ROHS COMPLIANCE.

NOTE: UNLESS OTHERWISE SPECIFIED

UNLESS OTHERWISE SPECIFIED DIMENSIONS IN INCHES [MM] TOLERANCES ARE: DECIMALS DECIMALS ANGLES XX±.02[.5] .XXX±.010[.25] ± 1/2 DEBURR EDGES .010 [.25] R MAX	APPROVALS	DATE (DD-MMM-YY)	QSC AUDIO PRODUCTS, LLC 1675 MACARTHUR BOULEVARD COSTA MESA, CA 92626 SPEAKER ASSY, KW152
	DRAWN R. SHIMA	26-APR-10	
	CHECKED J. CHAVEZ	24-MAY-10	
	MFG ENG D. GALVAN	21-MAY-10	
FINISH	QA CHECK D. BROWN	19-MAY-10	SIZE CAGE CODE DRAWING NO. REV D 00PW4 WP-215200-01 A
DRAWING INFO: WP-215200-01 .A.5		SCALE: 0.188	DO NOT SCALE DRAWING SHEET 1 OF 2
MODEL INFO: WP-215200-01 .A.3			

Assembly Item Number:WP-215200-01 Assembly Description:SPEAKER ASSY,,KW152,BLK,,UNIV SPLY,FULL RNG,15" 2-WAY

Part Number	Description	Item No.	Qty
CH-000525-GP	HANDLE BAR, , , HPR122i,	1	2
CH-001020-00	GRILLE, 15", , KW152,	2	1
MS-000403-00	FOOT, PLASTIC, WL212-sw, ,	3	4
MS-000423-00	INSULATION DAMPING, WL2102-sw, , ,	4	3
NW-000046-00	WSHR, FLT, , , .281 ID, .625 OD, .062 THK. TOL. +/- .010, STL, BLK, ZINC, CR3	5	4
NW-000168-00	WSHR, RTNR, M8, , , , STL, CLR, ZINC CR3,	6	2
NW-264815-09	WSHR, LCK, 0.26, SPLIT, , , .062, STL, BLK, ZINC,	7	4
PA-000268-00	FLEXIBLE LIGHT PIPE ASSY, DOME FACE, SM ADAPTER, 2.09", KW152/153/LXT315	8	1
PA-000271-00	TILT DIRECT ASSY, KW SERIES, , ,	9	1
PL-000501-GP	HANDLE CUP, , , , ,	10	2
PL-000703-00	HORN, HF, KW152, , ,	11	1
PL-000720-00	LOGO, QSC, KW152/153/181, , ,	12	1
SC-000027-00	PHILLIPS, ROUNDHEAD, , , , #8, 0.5" L, WOOD, , BLACK, PHOS, 6219 LUBE,	14	2
SC-000214-00	SCR, PHH, PHN, MACH, , , , M5, 20 L, STL CLASS 4.6, BLK, ZINC CR3, ND PATCH MDM	15	4
SC-000215-00	SCR, PHH, PNH, MACH, , , , M5, 30 L, STL CLASS 4.6, BLK, ZINC CR3,	16	12
SC-000226-00	SCR, HEX SKT, FLH, MACH, , , , M10, 25 L, STL CLASS 10.9, BLK, ZINC CR3,	17	11
SC-000255-00	SCR, PPH, PNH, , , , , M5, 25 L, STL, BLK, ZINC CR3, 9.0 MAX HD,	18	8
SC-000259-00	SCR, PHH, PNH, PARTICLE BD, , , , #10, 5/8 L, CARBON STL, BLK, ZINC, CR3,	19	40
SC-000307-00	SCR, HEXHD CAP, CAP, , , , , M6, 25 L, STL, BLK, ZINC CR3,	20	4
SC-000348-00	SCR, PHH, PNH, PARTICLE BOARD, , , , #10, 1" L, CARBON STL, BLK, ZINC CR3,	21	12
SP-000184-00	COMPRESSION DRIVER, , , , 1.75", PETP, NEODYMIUM, CELESTION, K/KW SERIES	22	1
WC-000513-00	WIRE HARNESS, , , , KW122/152, ,	23	1
WP-212203-00	PCB ASSY, LED, SPKR, , GRILLE	24	1
WP-215204-00	TOP COVER ASSY, , KW152, , UNIV SPLY, FULL RNG, 15" 2-WAY	25	1
XD-000002-00	WOOFER, 15", , PAPER, CERAMIC, CELESTION, KW152	26	1