

THIS DOCUMENT CONTAINS PROPRIETARY INFORMATION WHICH IS THE PROPERTY OF QSC, LLC. THAT MAY NOT BE DISCLOSED, REPRODUCED OR USED WITHOUT EXPRESS WRITTEN CONSENT FROM QSC, LLC.

REVISIONS					
REV	ECO	DESCRIPTION	BY	EFF DATE	ISSUED
A	-	RELEASE		-	-

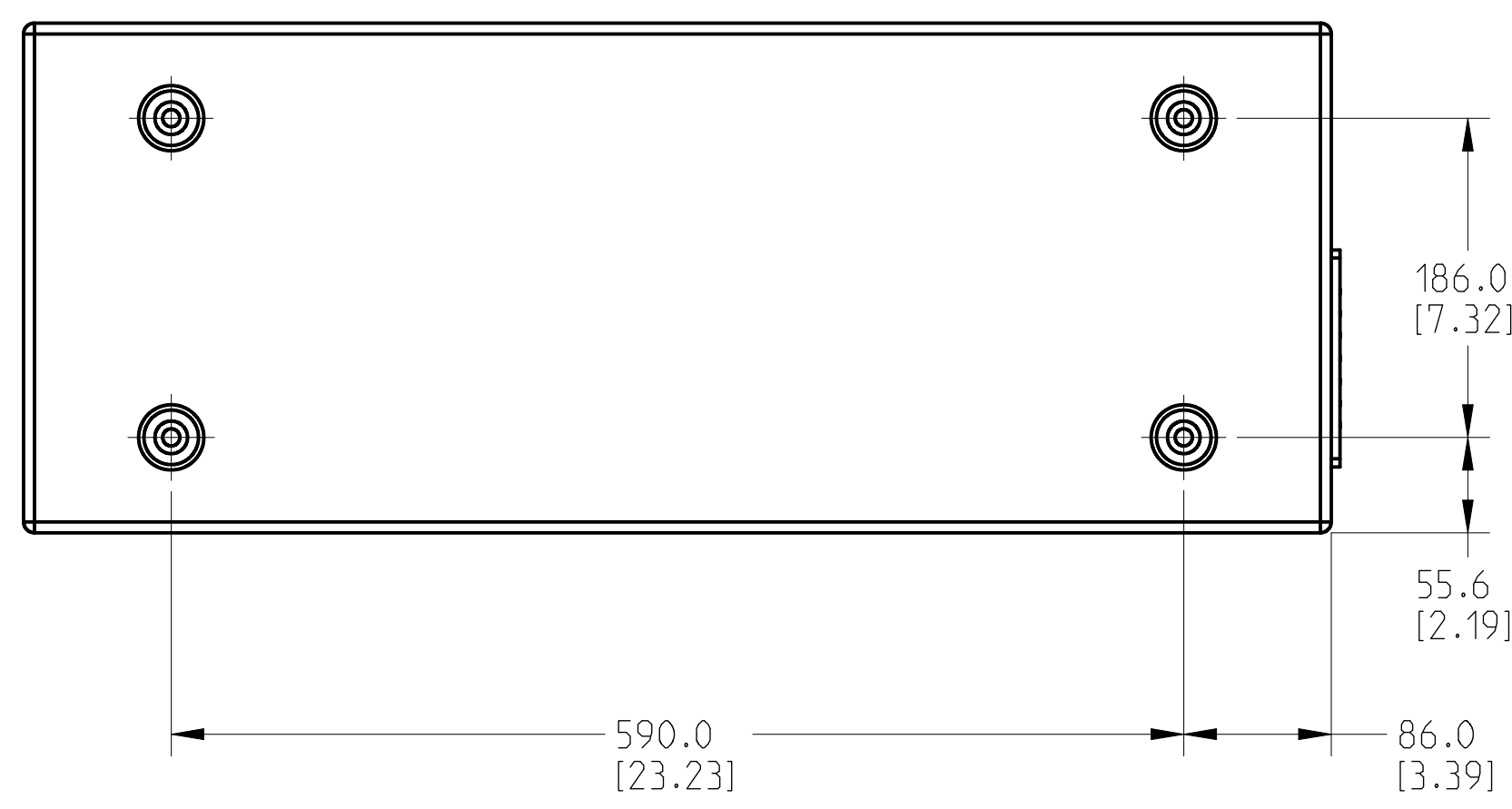
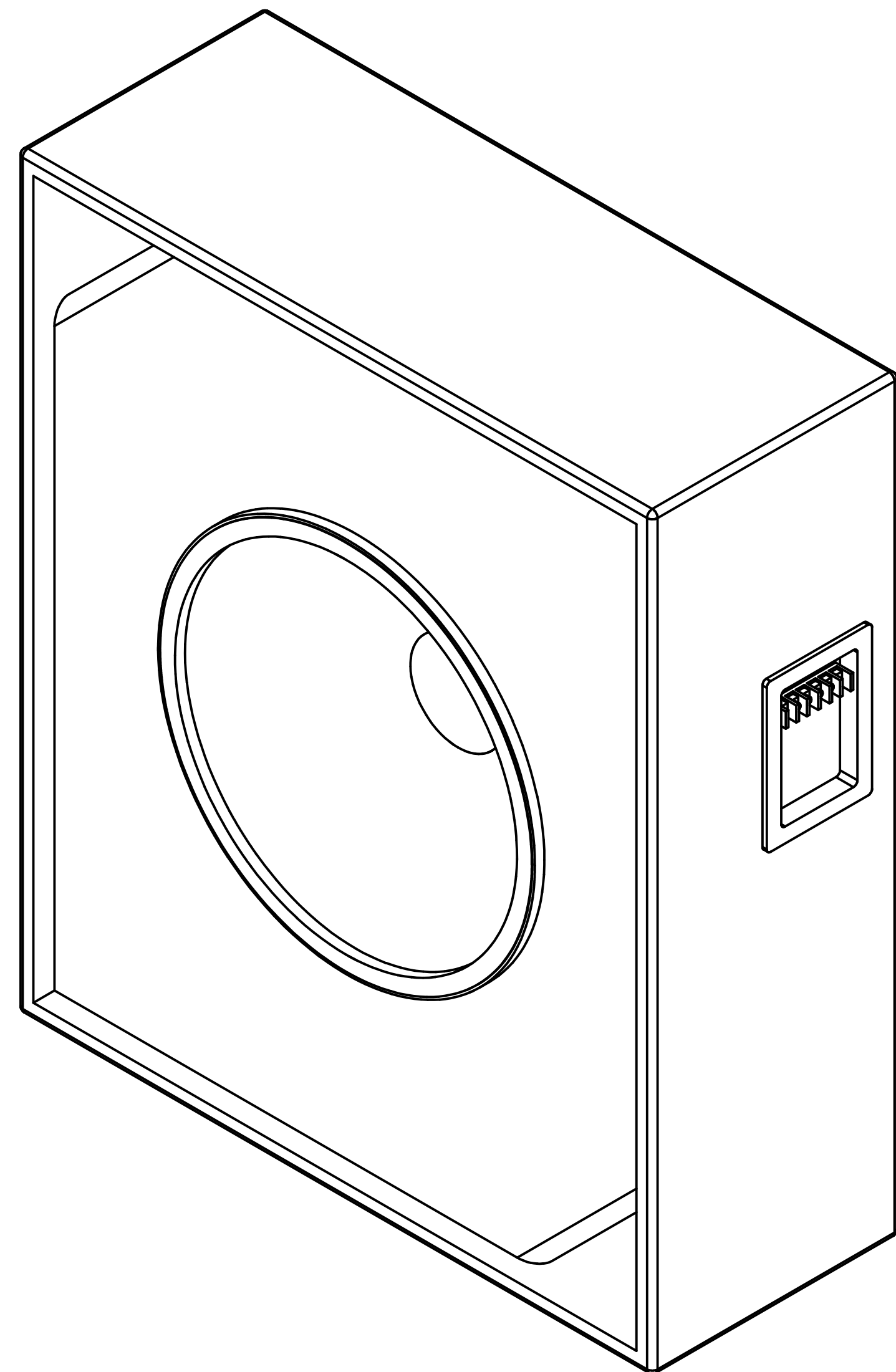
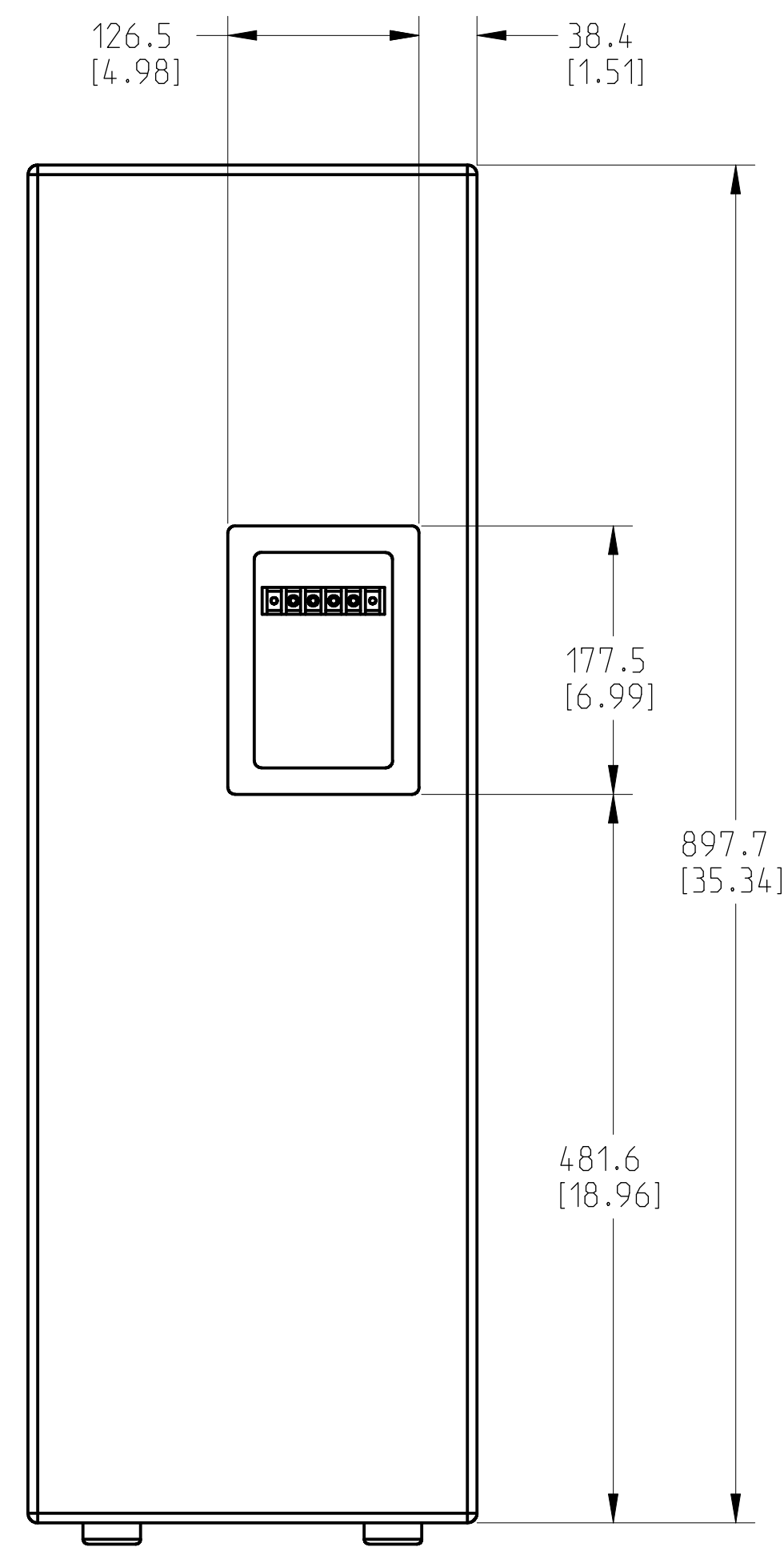
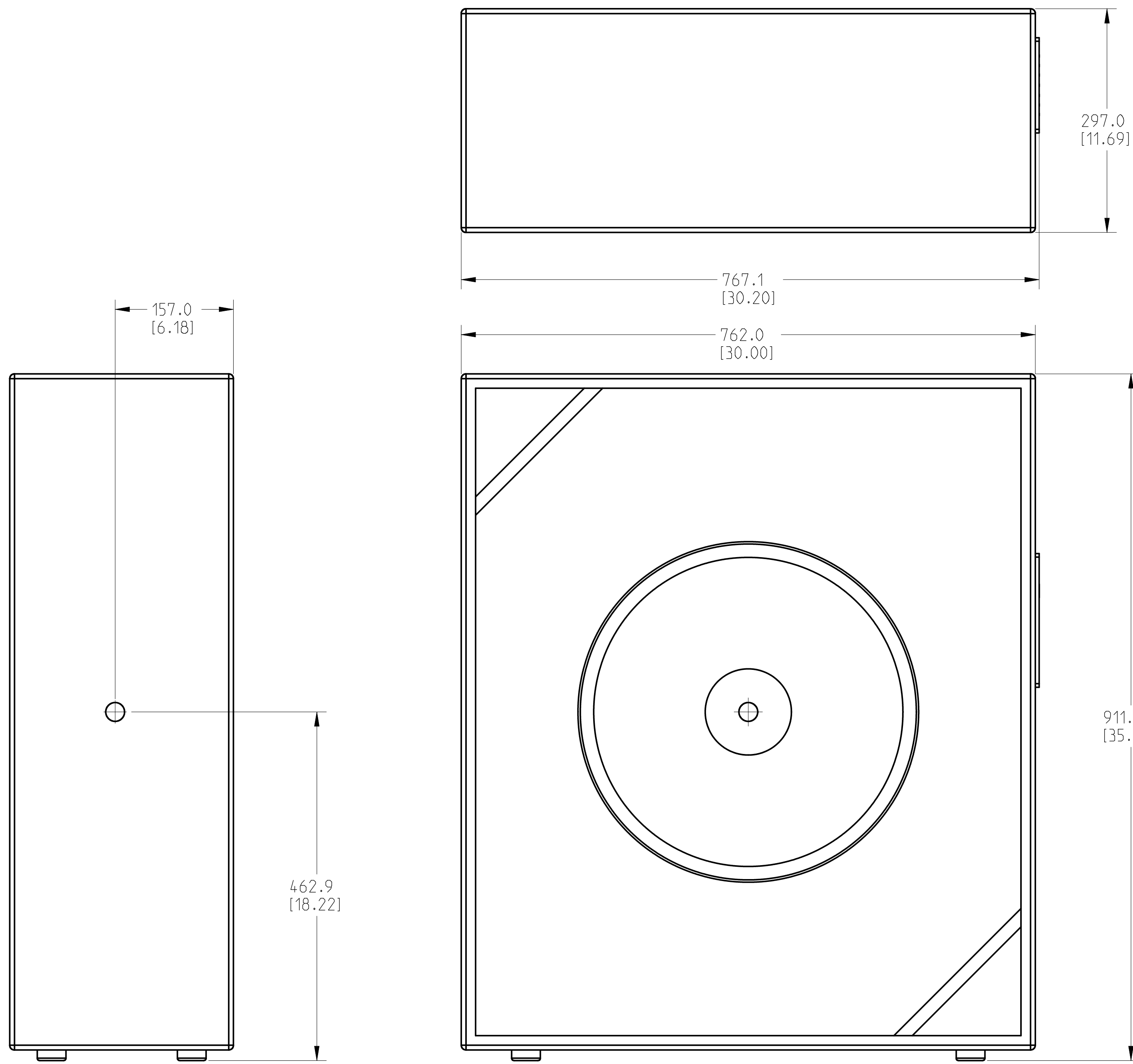

4. PARTS ARE SYMMETRICAL ABOUT CENTER LINES UNLESS OTHERWISE NOTED.
 3. SYMBOL ⊕ INDICATES CENTER OF BALANCE.
 2. TOLERANCES (MM): X ± 5, ANGLES: ± 1°.
 1. NET WEIGHT APPROX. 39.5(87.0) (KG/LBS).
- NOTE: UNLESS OTHERWISE SPECIFIED

UNLESS OTHERWISE SPECIFIED DIMENSIONS IN MILLIMETERS (IN) TOLERANCES ARE: DECIMALS .X±.5(1.02) ANGLES ±.25(1.0°) ± 1/2 DECORR EDGES .25 (1.01) R MAX MATERIAL FINISH	DESIGNER		QSC, LLC 1675 MACARTHUR BOULEVARD COSTA MESA, CA 92626	SPEAKER, FINISHED, 18" SUB, SB-1180		
	ENGINEER SERVICES	11/11/13		SIZE	CAGE CODE	DRAWING NO.
	TECHNICAL DIRECTOR			D	00PW4	WP-001185-2D
	MANUFACTURING ENGINEER			SCALE:	DO NOT SCALE DRAWING	SHEET
	DRAWING INFO: WP-001185-2D.A.0				REV	
	MODEL INFO: WP-001185-3D.A.0				A	
					1 OF 1	