



# AD-CI52ST/CI52T

AcousticDesign Ceiling Speakers

## Features

- **Wide bandwidth, high fidelity performance**—ensures a full, rich, musical sound with low distortion
- **Shares driver technology with AD-S (surface mount) loudspeakers for seamless sonic integration**—provides the ability to mix speaker models within zones for the best possible coverage
- **AD-CI52ST employs shallow can**—can be mounted in ceilings and standard architectural walls.
- **True high fidelity, 2-way design**—speakers feature a 1" titanium HF dome tweeter for exceptional sound quality from a ceiling format loudspeaker.



QSC's new AcousticDesign™ "C" Series represents the state-of-the-art in in-ceiling speakers. Delivering exceptional sound quality and value for background music and paging systems, the AD-CI52T and AD-CI52ST are ideal for a wide range of business applications, including hotels, restaurants and pubs, corporate offices, retail spaces, convention centers, recreation facilities, churches, airports, etc.

Featuring an unusually wide frequency range and the ability to deliver higher SPLs, the AcousticDesign Series loudspeakers provide natural sounding lows and transparent highs for a truly musical sound with very low distortion. Coupled with wide and even dispersion, the AD-CI52T and AD-CI52ST deliver outstanding coverage.

The AcousticDesign "C" Series ceiling speakers employ a 5.25" weather-resistant LF transducer incorporating a low distortion fiberglass cone, a 25 mm voice coil, and a rubber surround. The HF driver is a 1" pure titanium dome tweeter utilizing a neodymium magnet structure. With its larger, ported enclosure, the AD-CI52ST provides greater low-frequency extension and makes an excellent choice for installations requiring shallow install depth—such as cruise ships. By contrast, the AD-CI52T has a smaller "footprint"—enabling this speaker to be less visually intrusive. While both models are weather resistant, the AD-CI52T, by not being a ported enclosure, carries the added benefit of being a fully sealed speaker system.

The AcousticDesign ceiling speakers are packaged with the backcan, support bracket, tile rails, and a grille. For integration with any décor, the trim and grille can be painted. Additionally, these speakers are well suited for use in air handling spaces per UL2043 and UL1480. There is also a seismic tab provided for secondary support.

## Specifications

	AD-CI52ST	AD-CI52T
Configuration	Shallow can, 2-way, ported enclosure	Compact 2-way, sealed enclosure
Transducers		
Low-frequency Transducers	5.25" (13 cm) weather resistant, low distortion fiberglass cone woofer, 25 mm voice coil, rubber surround	5.25" (13 cm) weather resistant, low distortion fiberglass cone woofer, 25 mm voice coil, rubber surround
High-frequency Transducer	1" titanium dome tweeter, neodymium magnet	1" titanium dome tweeter, neodymium magnet
Frequency Range <sup>1</sup>		
Frequency Response (-6 dB)	63 Hz - 20 kHz	85 Hz - 20 kHz
Useable Frequency Range (-10 dB)	53 Hz - 20 kHz	65 Hz - 20 kHz
Maximum Output <sup>2</sup>		
Calculated Peak Output	109 dB SPL	108 dB SPL
Calculated Continuous Output	103 dB SPL	102 dB SPL
Nominal Impedance	8Ω	8Ω
Power Rating		
RMS Power Handling <sup>3</sup>	40 W (100 hours IEC)	40 W (100 hours IEC)
Recommended Max Amp Power	80 W RMS	80 W RMS
Sensitivity	87.5 dB, 2.83 V, 1 m, flush mounted (2π)	86 dB, 2.83 V, 1 m, flush mounted (2π)
Nominal Coverage	100° conical pattern	90° conical pattern
Bass Loading	Ported, tuned to 70 Hz	Sealed
Transformers		
Type	Custom low distortion laminated core, wide bandwidth design	
Taps	70/100 V: 30, 15, 7.5, 3.8 W and 8Ω selected by switch	
Insertion Loss	0.8 dB, averaged over 50 Hz - 20 kHz bandwidth (30 W tap)	
Distortion	< .01% THD above 100 Hz, 0.2% at 50 Hz (30 W tap)	
Bandwidth	40 Hz - 20 kHz (-1 dB, all taps)	
Enclosure		
Material	Injection molded, high impact polystyrene baffle on a steel enclosure	
Finish	White (paintable)	
Grille	Heavy duty powder coated steel	
Connectors	4-pin Euro terminals in fire protective sub-chamber	
Mounting Hardware	Rails and brackets for ceiling tile installation	
Weight - Net / Shipping (pair)	8 lb (3.6 kg) / 27 lb (12.2 kg)	7.5 lb. (3.4 kg) / 24 lb (10.9 kg)
Available Accessories	ADC-MRS Mud ring bracket ADC-NCS New construction bracket	ADC-MR Mud ring bracket ADC-NC New construction bracket

1) All frequency ranges specified refer to measured free field response (half space, 2π).

2) Calculated SPL at 1m, (half space, 2π), speaker operating at rated RMS power with pink noise within specified frequency range

3) Maximum input power tested in accordance with IEC 268-5 recommendations, 50 Hz - 20 kHz band limiting, 6 dB signal crest factor.

# AD-CI52ST/CI52T

## Dimensions | Frequency Response

### AD-CI52ST

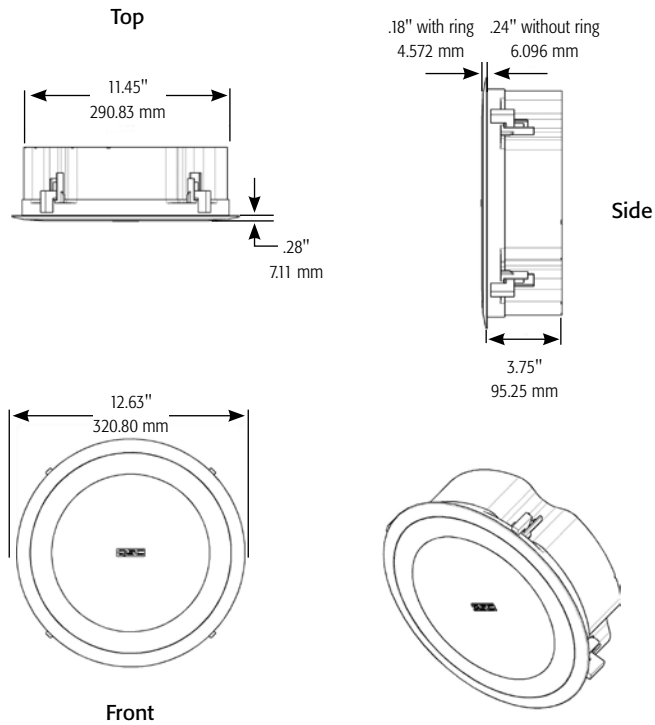

### AD-CI52T

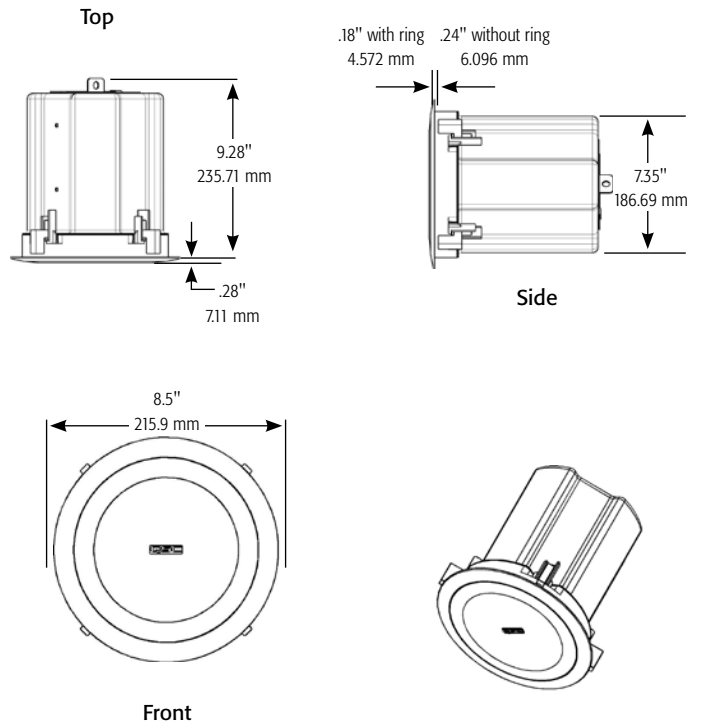

**AD-CI52ST**  
 Frequency Response  
 ( $2\pi$ ,  $8\Omega$ )

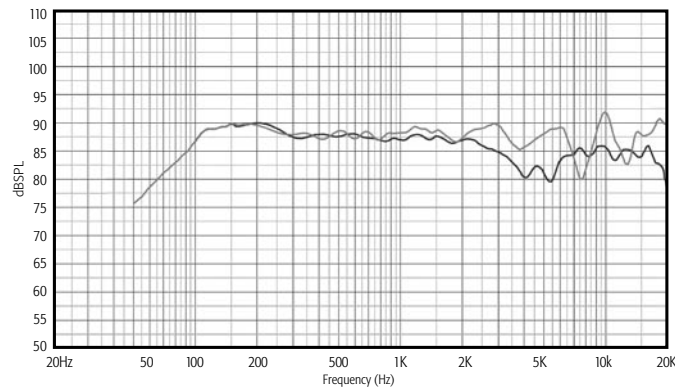

**AD-CI52T**  
 Frequency Response  
 ( $2\pi$ ,  $8\Omega$ )

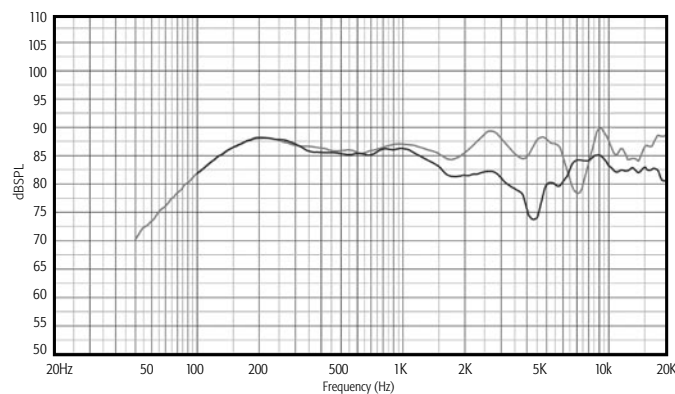

Specifications subject to change without notice.